

2025



Garage Equipment Center

مركز معدات خدمة السيارات





ص - ٣

حلول مراكز الغسيل



ص - ٢٤

حلول معدات النظافة



ص - ٢٦

حلول معدات الإطارات



ص - ٤١

حلول معدات الميكانيكا



ص - ٥٦

حلول معدات الزيوت والشحوم



ص - ٧٢

حلول مراكز شحن الفريون



ص - ٧٥

حلول مراكز الكهرباء



ص - ٨١

حلول الهواء المضغوط

A dark-colored car is being washed in a car wash. A high-pressure water spray is directed at the car's side panel. The background shows the interior of the car wash with tiled walls and various equipment.

حلول مراکز الغسيل



طلمبات غسيل ضغط عالي High Pressure Water Pump

Garage Equipment Center GEC offers a full range of high-pressure pumps, produced by Interamp Group and Odor, which are one of the largest manufacturers of piston pumps in the world, which are manufactured very professionally to meet all the needs of the market and ensure that all fields are covered

- Pumps for the industrial character with pressures starting from 10 bar up to 500 bar.
- Special pumps for working at high temperatures at a temperature of up to 85°C.
- Low pumps made of stainless steel to work in the dairy, food and industries chemical and pharmaceutical industry.
- A variety of pumps that work on hydraulic systems.



قطع غيار اصلية و معتمدة Original and Granited Spear Parts

- Interpump Group is an Italian company specialized in the Manufacture of pumps high pressure and hydraulic drives. It was founded in 1977 and has More than 40 subsidiaries and Interpump Group offers innovative and high-end solutions Quality for various sectors, such as pressure washing.



قطع غيار اصلية و معتمدة Original and Granited Spear Parts

- Udor is a leading manufacturer of water pumps for various applications. The company offers a full range of pumps for agricultural use and industrial and residential. Udor pumps are characterized by quality and reliability and durability. The company was founded in 1966 in Italy and produces pumps Submersible, transport, centrifuge, piston and membrane.



طلمبات غسيل ضغط عالي High Pressure Water Pump



AB150/SMOOTH

PRATISSOLI/KF40



W170

WS151

W202

W4018

W5015



E3B2121

E2B1713

SS3B2021

Technical details

● Model	WS202	W4018	W5015	AB150SMOOTH	PRATISSOLI/KF40	● موديل
● Flow Rate	21 L/min	18 L/min	15 L/min	150 L/min	170 L/min	● التصريف
● Operating Pressure	200 Bar	400 Bar	500 Bar	60 Bar	110 Bar	● ضغط الطلمبة
● Motor Power	10 Hp	20 Hp	20 Hp	23.4 Hp	49 Hp	● قدرة الموتور
● Power Supply	380 V	380 V	380 V	380 V	380 V	● مصدر الكهرباء
● Motor Speed	1450 RPM	1450 RPM	1450 RPM	550 RPM	900 RPM	● عدد لفات الموتور
● Head Of Pump	Nickle	Brass	Brass	Cast Iron	Nickle	● رأس المضخة

10114

10117

10118

1011208

101120

المواصفات الفنية

Technical details

● Model	E3B2121	E3B1713	SS3B2021	WS170	WS151	● موديل
● Flow Rate	21 L/min	13 L/min	21 L/min	9.5 L/min	15 L/min	● التصريف
● Operating Pressure	210 Bar	170 Bar	200 Bar	170 Bar	150 Bar	● ضغط الطلمبة
● Motor Power	10 Hp	5.7 Hp	10.9 Hp	4 Hp	5.5 Hp	● قدرة الموتور
● Power Supply	380 V	220 V	380 V	220V	380 V	● مصدر الكهرباء
● Motor Speed	1450 RPM	1450 RPM	1450 RPM	1450 RPM	1450 rpm	● عدد لفات الموتور
● Head Of Pump	Nickle	Brass	Stainless Steel	Brass	Brass	● رأس المضخة

1011207

1011205

101131

101111

10113

المواصفات الفنية



طلمبات غسيل ضغط عالي High Pressure Water Pump

**BC20-15BRASS****CC20-16BRASS****CC 70-15 BRASS****PKC17-13NICKLE****VX-B160-130 R****PNC11-14NICKLE****CXC 22-50 BRASS****BC20-21NICKLE****Technical details**

	BC 15-20	CC 26-20	CC 70-15	CXC 15-50	VX-B 160/130 R	المواصفات الفنية
● Model	BC 15-20	CC 26-20	CC 70-15	CXC 15-50	VX-B 160/130 R	● موديل
● Flow Rate	15 L/min	26 L/min	70 L/min	15 L/min	160 L/min	● التصريف
● Operating Pressure	200 Bar	200 Bar	150 Bar	500 Bar	130 Bar	● ضغط الطلمبة
● Motor Power	7.5 Hp	13.6 Hp	26.9 Hp	20 HP	52.3 Hp	● قدرة الموتور
● Power Supply	380 V	380 V	380 V	380 V	380 V	● مصدر الكهرباء
● Motor Speed	1450 RPM	1450 RPM	1450 RPM	1450 RPM	1000 RPM	● عدد لفات الموتور
● Head Of Pump	Brass	Brass	Brass	Brass	Brass	● رأس المضخة

10167**101611****101615****101612****101632****Technical details**

	PNC 11-14	CXC 50-22	BC 21-20	المواصفات الفنية
● Model	PNC 11-14	CXC 50-22	BC 21-20	● موديل
● Flow Rate	11 L/min	22 L/min	21 L/min	● التصريف
● Operating Pressure	140 Bar	500 Bar	200 Bar	● ضغط الطلمبة
● Motor Power	4 Hp	28 Hp	10 Hp	● قدرة الموتور
● Power Supply	220 V	380 V	380 V	● مصدر الكهرباء
● Motor Speed	1450 RPM	1450 RPM	1450 RPM	● عدد لفات الموتور
● Head Of Pump	Brass	Brass	Nickle	● رأس المضخة

101613**101619****10168**



ماكينات غسيل بارد ضغط عالي High Pressure Water Pump

Suitable For مناسبة

AUTOMOTIVE	
AGRICULTURE	
CONSTRUCTION INDUSTRY	
MUNICIPALITIES	
HEAVY INDUSTRY	



Technical details

● Model	GEC.DRAGON 25/250	GEC.DRAGON 18/400	GEC.DRAGON 15/500	● موديل
● Flow Rate	25 L/min	18 L/min	15 L/min	● التصريف
● Operating Pressure	250 Bar	400 Bar	500 Bar	● ضغط الظلمية
● Motor Power	20 Hp	20 Hp	20 Hp	● قدرة الموتور
● Power Supply	380 V	380 V	380 V	● مصدر الكهرباء
● Motor Speed	1450 RPM	1450 RPM	1450 RPM	● عدد لفات الموتور

10236

10237

10238

المواصفات الفنية



ماكينات غسيل بارد ضغط عالي High Pressure Water Pump

Suitable For مناسبة

AUTOMOTIVE	
AGRICULTURE	
CONSTRUCTION INDUSTRY	
MUNICIPALITIES	
DIY AND GARDENING	
HEAVY INDUSTRY	



DRAGON/3HP

DRAGON/4HP

DRAGON/7.5HP

DRAGON/10HP

Technical details

● Model	G.DRAGON 10/130	G.DRAGON 11/140	G.DRAGON 15/200	DRAGON/10HP	● موديل
● Flow Rate	10 L/min	11 L/min	15 L/min	21 L/min	● التصريف
● Operating Pressure	130 Bar	140 Bar	200 Bar	200 Bar	● ضغط الظلمية
● Motor Power	3 Hp	4 Hp	7.5 Hp	10 Hp	● قدرة الموتور
● Power Supply	220 V	220 V	380 V	380 V	● مصدر الكهرباء
● Motor Speed	1450 RPM	1450 RPM	1450 RPM	1450 RPM	● عدد لفات الموتور

10231

102102

10233

10234

المواصفات الفنية



E.Jet Series



Suitable For مناسبة

AUTOMOTIVE	<input type="checkbox"/>
AGRICULTURE	<input type="checkbox"/>
CONSTRUCTION INDUSTRY	<input type="checkbox"/>
MUNICIPALITIES	<input type="checkbox"/>
DIY AND GARDENING	<input type="checkbox"/>
HEAVY INDUSTRY	<input type="checkbox"/>



وحدة غسيل بارد High Pressure Washing Unit

Technical details

Model	E.JET/15/200	E.JET/21/210	E.JET/15/250	موديل
Flow Rate	15 L/min	21 L/min	15 L/min	التصريف
Operating Pressure	200 Bar	210 Bar	250 Bar	ضغط الظلمية
Motor Power	7.5 Hp	10 Hp	10 Hp	قدرة الموتور
Power Supply	380 V	380 V	380 V	مصدر الكهرباء
Motor Speed	1450 RPM	1450 RPM	1450 RPM	عدد لفات الموتور

102713

102714

102715

المواصفات الفنية



E.Jet Series



Suitable For مناسبة

AUTOMOTIVE	<input type="checkbox"/>
AGRICULTURE	<input type="checkbox"/>
CONSTRUCTION INDUSTRY	<input type="checkbox"/>
MUNICIPALITIES	<input type="checkbox"/>
DIY AND GARDENING	<input type="checkbox"/>
HEAVY INDUSTRY	<input type="checkbox"/>



وحدة غسيل بارد High Pressure Washing Unit

Technical details

Model	E.JET/13/130	E.JET/15/150	E.JET/13/170	موديل
Flow Rate	13 L/min	15 L/min	13 L/min	التصريف
Operating Pressure	130 Bar	150 Bar	170 Bar	ضغط الظلمية
Motor Power	3 Hp	5 Hp	4 Hp	قدرة الموتور
Power Supply	220 V	220 V	220 V	مصدر الكهرباء
Motor Speed	1450 RPM	1450 RPM	1450 RPM	عدد لفات الموتور

1027116

102712

102711

المواصفات الفنية



U.Jet Series



380v

Suitable For مناسبة

AUTOMOTIVE	✓
AGRICULTURE	✓
CONSTRUCTION INDUSTRY	✓
MUNICIPALITIES	✓
DIY AND GARDENING	✓
HEAVY INDUSTRY	✓



وحدة غسيل بارد High Pressure Washing Unit

Technical details

Model	U.JET/15/200	U.JET/21/200	U.JET/250/15	موديل
Flow Rate	15 L/min	21 L/min	15 L/min	التصريف
Operating Pressure	200 Bar	200 Bar	250 Bar	ضغط الطلمبة
Motor Power	7.5 Hp	10 Hp	10 Hp	قدرة الموتور
Power Supply	380 V	380 V	380 V	مصدر الكهرباء
Motor Speed	1450 RPM	1450 RPM	1450 RPM	عدد لفات الموتور

10294

10295

10296

المواصفات الفنية



U.Jet Series



220v

Suitable For مناسبة

AUTOMOTIVE	✓
AGRICULTURE	✓
CONSTRUCTION INDUSTRY	✓
MUNICIPALITIES	✓
DIY AND GARDENING	✓
HEAVY INDUSTRY	✓



وحدة غسيل بارد High Pressure Washing Unit

Technical details

Model	U.JET/11/120	U.JET/15/150	U.JET/13/170	موديل
Flow Rate	11 L/min	15 L/min	13 L/min	التصريف
Operating Pressure	120 Bar	150 Bar	170 Bar	ضغط الطلمبة
Motor Power	3 Hp	5 Hp	4 Hp	قدرة الموتور
Power Supply	220 V	220 V	220 V	مصدر الكهرباء
Motor Speed	1450 RPM	1450 RPM	1450 RPM	عدد لفات الموتور

10291

102712

102711

المواصفات الفنية



G.JET MALE POWER CLEAN



وحدة غسيل بارد High Pressure Washing Unit



Suitable For مناسبة

AUTOMOTIVE	■
AGRICULTURE	■
CONSTRUCTION INDUSTRY	■
MUNICIPALITIES	■
DIY AND GARDENING	■
HEAVY INDUSTRY	■

Technical details

● Model	G.JET MALE POWER CLEAN	● موديل
● Flow Rate	15 L/min	● التصريف
● Operating Pressure	200 Bar	● ضغط الظلمية
● Motor Power	7.5 Hp	● قدرة الموتور
● Power Supply	380 V	● مصدر الكهرباء
● Motor Speed	1450 RPM	● عدد لفات الموتور

10241

المواصفات الفنية



U.JET MALE POWER CLEAN



وحدة غسيل بارد High Pressure Washing Unit



Suitable For مناسبة

AUTOMOTIVE	■
AGRICULTURE	■
CONSTRUCTION INDUSTRY	■
MUNICIPALITIES	■
DIY AND GARDENING	■
HEAVY INDUSTRY	■

Technical details

● Model	U.JET MALE POWER CLEAN	● موديل
● Flow Rate	15 L/min	● التصريف
● Operating Pressure	200 Bar	● ضغط الظلمية
● Motor Power	7.5 Hp	● قدرة الموتور
● Power Supply	380 V	● مصدر الكهرباء
● Motor Speed	1450 RPM	● عدد لفات الموتور

10246

المواصفات الفنية



G.JET WASH BOX



Suitable For مناسبة

AUTOMOTIVE	
AGRICULTURE	
CONSTRUCTION INDUSTRY	
MUNICIPALITIES	
DIY AND GARDENING	
HEAVY INDUSTRY	



وحدة غسيل بارد High Pressure Washing Unit

Technical details

● Model	G.JET WASH BOX/15/200
● Flow Rate	15 L/min
● Operating Pressure	200 Bar
● Motor Power	7.5 Hp
● Power Supply	380 V
● Motor Speed	1450 RPM

المواصفات الفنية

● موديل	G.JET WASH BOX/15/200
● التصريف	15 L/min
● ضغط الطلمبة	200 Bar
● قدرة الموتور	7.5 Hp
● مصدر الكهرباء	380 V
● عدد لفات الموتور	1450 RPM

102114



U.JET WASH BOX



Suitable For مناسبة

AUTOMOTIVE	
AGRICULTURE	
CONSTRUCTION INDUSTRY	
MUNICIPALITIES	
DIY AND GARDENING	
HEAVY INDUSTRY	



وحدة غسيل بارد High Pressure Washing Unit

Technical details

● Model	U.JET WASH BOX/15/200
● Flow Rate	15 L/min
● Operating Pressure	200 Bar
● Motor Power	7.5 Hp
● Power Supply	380 V
● Motor Speed	1450 RPM







المواصفات الفنية

● موديل	U.JET WASH BOX/15/200
● التصريف	15 L/min
● ضغط الطلمبة	200 Bar
● قدرة الموتور	7.5 Hp
● مصدر الكهرباء	380 V
● عدد لفات الموتور	1450 RPM

10299

PORTOTECNICA™ MADE IN ITALY
Galaxy-4H Series

Suitable For **مناسبة**

AUTOMOTIVE	
AGRICULTURE	
CONSTRUCTION INDUSTRY	
MUNICIPALITIES	
DIY AND GARDENING	
HEAVY INDUSTRY	

Technical details

● Temperature	30°C up to 140°C
● Flow Rate	17 L/min
● Operating Pressure	200 Bar
● Motor Power	8.5 Hp
● Detergent Tank	22 L
● Motor Speed	1400 RPM

10333

ماكينة غسيل ساخن/بارد
Hot/Cold High Pressure
Washing Machine





المواصفات الفنية

● درجة الحرارة	30°C up to 140°C
● التصريف	17 L/min
● ضغط الظلمية	200 Bar
● قدرة الموتور	8.5 Hp
● خزان منظفات داخلي	22 L
● عدد لفات الموتور	1400 RPM

PORTOTECNICA™ MADE IN ITALY
Synchr-H4 Series

Suitable For **مناسبة**

AUTOMOTIVE	
AGRICULTURE	
CONSTRUCTION INDUSTRY	
MUNICIPALITIES	
HEAVY INDUSTRY	

Technical details

● Temperature	30°C up to 140°C
● Flow Rate	22 L/min
● Operating Pressure	200 Bar
● Motor Power	11 Hp
● Detergent Tank	22 L
● Motor Speed	1400 RPM

10332

ماكينة غسيل ساخن/بارد
Hot/Cold High Pressure
Washing Machine



المواصفات الفنية

● درجة الحرارة	30°C up to 140°C
● التصريف	22 L/min
● ضغط الظلمية	200 Bar
● قدرة الموتور	11 Hp
● خزان منظفات داخلي	22 L
● عدد لفات الموتور	1400 RPM



PW-H100P Series



Suitable For **مناسبة**

- AUTOMOTIVE
- AGRICULTURE
- CONSTRUCTION INDUSTRY
- MUNICIPALITIES
- HEAVY INDUSTRY



ماكينة غسيل ساخن/بارد Hot/Cold High Pressure Washing Machine



Technical details

● Temperature	30°C up to 140°C	30°C up to 140°C	● درجة الحرارة
● Flow Rate	17 L/min	22 L/min	● التصريف
● Operating Pressure	200 Bar	200 Bar	● ضغط الطلمبة
● Motor Power	8.5 Hp	11 Hp	● قدرة الموتور
● Detergent Tank	22 L	22 L	● خزان منظفات داخلي
● Fuel Tank	25 L	25 L	● خزان البنزين

130221

103222

المواصفات الفنية



PW-H28

Suitable For **مناسبة**

- AUTOMOTIVE
- AGRICULTURE
- CONSTRUCTION INDUSTRY
- MUNICIPALITIES
- HEAVY INDUSTRY



ماكينة غسيل ساخن/بارد Hot/Cold High Pressure Washing Machine



Technical details

● Temperature	30°C up to 130°C	● درجة الحرارة
● Flow Rate	13.5 L/min	● التصريف
● Operating Pressure	170 Bar	● ضغط الطلمبة
● Motor Power	6.5 Hp	● قدرة الموتور
● Fuel Tank	18 L	● خزان البنزين

103223

المواصفات الفنية

PORTOTECNICA
IPC
PW-C55

MADE IN ITALY



ماكينة غسيل بارد Cold High Pressure Washing Machine

Suitable For **مناسبة**

AUTOMOTIVE	
AGRICULTURE	
CONSTRUCTION INDUSTRY	
MUNICIPALITIES	
DIY AND GARDENING	
HEAVY INDUSTRY	

Technical details

● Flow Rate	17 L/min
● Operating Pressure	210 Bar
● Motor Power	8.5 Hp
● Power Supply	380 V
● Motor Speed	1400 RPM

1031321



المواصفات الفنية

● التصريف
● ضغط الطلمبة
● قدرة الموتور
● مصدر الكهرباء
● عدد لفات الموتور

INTERPUMP GROUP
MADE IN ITALY
TX-Series



ماكينة غسيل بارد Cold High Pressure Washing Machine

Suitable For **مناسبة**

AUTOMOTIVE	
AGRICULTURE	
CONSTRUCTION INDUSTRY	
MUNICIPALITIES	
HEAVY INDUSTRY	

Technical details

● Model	TX130	TX130TTS	● مزود بنظام توليد سوب	TX150	TX180	● موديل
● Flow Rate	9.5 L/min	9.5 L/min	15 L/min	13 L/min	● التصريف	
● Operating Pressure	130 Bar	130 Bar	150 Bar	180 Bar	● ضغط الطلمبة	
● Motor Power	4.3 HP	4.3 Hp	6.7 Hp	6.7 Hp	● قدرة الموتور	
● Power Supply	220 V	220 V	380 V	380 V	● مصدر الكهرباء	
● Motor Speed	1450 RPM	1450 RPM	1450 RPM	2800 RPM	● عدد لفات الموتور	

10319

103114

10315

10316



المواصفات الفنية



ماكينات غسيل بارد ضغوط عالية High Pressure Water Pump

Suitable For مناسبة

AUTOMOTIVE	
AGRICULTURE	
CONSTRUCTION INDUSTRY	
MUNICIPALITIES	
HEAVY INDUSTRY	



Technical details

● Model	GEC G.DRAGON HONDA 15/200
● Flow Rate	15 L/min
● Operating Pressure	200 Bar
● Motor Power	13 Hp
● Power Supply	HONDA-GX390
● Motor Speed	1450 RPM

المواصفات الفنية

● موديل
● التصريف
● ضغط الظلمية
● قدرة الموتور
● مصدر الكهرباء
● عدد لفات الموتور

10251



ماكينات غسيل بارد ضغوط عالية High Pressure Water Pump

Suitable For مناسبة

AUTOMOTIVE	
AGRICULTURE	
CONSTRUCTION INDUSTRY	
MUNICIPALITIES	
DIY AND GARDENING	
HEAVY INDUSTRY	

G134-C



G151-CP



Technical details

● Model	G134-C	G151-CP
● Flow Rate	6.5 L/min	8.5 L/min
● Operating Pressure	120 Bar	150 Bar
● Motor Power	2.1 Hp	3.5 Hp
● Power Supply	220 V	220 V
● Motor Speed	1450 RPM	1450 RPM

المواصفات الفنية

● موديل
● التصريف
● ضغط الظلمية
● قدرة الموتور
● مصدر الكهرباء
● عدد لفات الموتور

103134

1031314

مكنسة شفط صناعي Industrial Vacuum Cleaner PLANET730H

PORTOTECNICA™ MADE IN ITALY
Planet Series



Features

- Visual Filling Indicator.
- Vacuum Relief Valve And Filtration Level Indicator.
- Filter Overpressure Indicators Safety Disposal Systems.
- Resistant Framework And Inlet Plug For Safe Transfer.

المميزات

- Reliable Construction For Intensive Use.
- Detachable Tank And Solid Cart.
- Manual Filter Shaker.
- Tangential Or Metal Inlet.
- Multi-Stage Filtration.

Technical details

● Usage	Dry	● استخدام
● Number Of Phases	3 Stages	● عدد المراحل
● Voltage/Frequency	60-50/380 V/Hz	● الجهد / التردد
● Turbine	1 Single-stage	● التوربين
● Power	2200 W	● قوة
● Airflow	275 m ³ /h	● تدفق الهواء
● Tank Capacity	60 Liter	● سعة الخزان
● Diameter Of Inlet	70 mm	● قطر المدخل
● Sound Pressure Level	74 dB(A)	● مستوى ضغط الصوت

المواصفات الفنية

11015

PORTOTECNICA™ MADE IN ITALY
Planet Series



مكنسة شفط صناعي Industrial Vacuum Cleaner PLANET50P



Features

- Visual Filling Indicator.
- Vacuum Relief Valve And Filtration Level Indicator.
- Filter Overpressure Indicators Safety Disposal Systems.
- Resistant Framework And Inlet Plug For Safe Transfer.

المميزات

- Reliable Construction For Intensive Use.
- Detachable Tank And Solid Cart.
- Manual Filter Shaker.
- Tangential Or Metal Inlet.
- Multi-Stage Filtration.

Technical details

● Usage	Dry	● استخدام
● Number Of Phases	3 Stages	● عدد المراحل
● Voltage/Frequency	60-50/380 V/Hz	● الجهد / التردد
● Turbine	1 Single-stage	● التوربين
● Power	3000 W	● قوة
● Airflow	250 m ³ /h	● تدفق الهواء
● Tank Capacity	50 Liter	● سعة الخزان
● Diameter Of Inlet	60 mm	● قطر المدخل
● Sound Pressure Level	69 dB(A)	● مستوى ضغط الصوت

المواصفات الفنية

11013

PORTOTECNICA MADE IN ITALY
IPC
Vaccums Series



مكنسة شفط مياه و اترية
Wet And Dry
Vaccum Cleaner
PLUS 1 W2 60S

Suitable For **مناسبة**
AUTOMOTIVE



HORECA
EDUCATION
OFFICE

Features

المميزات



Technical details

المواصفات الفنية

● Number Of Motors	3 Motors	● عددالموتير
● Number Of Phases	3 Stages	● عدد المراحل
● Pump	1 Pump	● مصدر الكهرباء
● Voltage	220 V	● ظلمبة ضخ
● Power	2400 W	● قوة
● Tank Capacity	60 Liter	● سعة الخزان

11017

PORTOTECNICA MADE IN ITALY
IPC
Vaccums Series



مكنسة شفط مياه و اترية
Wet And Dry
Vaccum Cleaner
NEVADA640

Suitable For **مناسبة**

AUTOMOTIVE

HARDWARE CUSTOMER

CONSTRUCTION

LOGISTIC & TRANSPORT

HEAVY INDUSTRY



Features

المميزات



Technical details

المواصفات الفنية

● Number Of Motors	3 Motors	● عددالموتير
● Number Of Phases	3 Stages	● عدد المراحل
● Voltage	220 V	● مصدر الكهرباء
● Power	3300 W	● قوة
● Tank Capacity	78 Liter	● سعة الخزان

11019



Vaccums Series



مكنسة شفط مياه و اترية Wet And Dry Vaccum Cleaner GEC-MNS80

Sutable For مناسبة

AUTOMOTIVE

HARDWARE CUSTOMER

CONSTRUCTION

LOGISTIC & TRANSPORT

HEAVY INDUSTRY



Technical details

المواصفات الفنية	Technical details	
● عددالموتير	3 Motors	● Number Of Motors
● عدد المراحل	2 Stages	● Number Of Phases
● مصدر الكهرباء	220 V	● Voltage
● قوة	3000 W	● Power
● سعة الخزان	80 Liter	● Tank Capacity

11034



Vaccums Series



مكنسة شفط مياه و اترية Wet And Dry Vaccum Cleaner GEC-POXA80

Sutable For مناسبة

AUTOMOTIVE

HARDWARE CUSTOMER

CONSTRUCTION

LOGISTIC & TRANSPORT

HEAVY INDUSTRY



Technical details

المواصفات الفنية	Technical details	
● عددالموتير	3 Motors	● Number Of Motors
● عدد المراحل	2 Stages	● Number Of Phases
● مصدر الكهرباء	220 V	● Voltage
● قوة	3000 W	● Power
● سعة الخزان	80 Liter	● Tank Capacity

11031

PORTOTECNICA IPC **MADI IN ITALY**
Vaccums Series



مكنسة شفط مياه و اترية Wet And Dry Vaccum Cleaner PLUS 1 W1 32S

Sutable For **مناسبة**

AUTOMOTIVE	
HARDWARE CUSTOMER	
CONSTRUCTION	
LOGISTIC & TRANSPORT	
HEAVY INDUSTRY	



Technical details

المواصفات الفنية

● Number Of Motors	1 Motor	● عددالموتير
● Number Of Phases	1 Phase	● عدد المراحل
● Voltage	220 V	● مصدر الكهرباء
● Power	1200 W	● قوة
● Tank Capacity	32 Liter	● سعة الخزان
● Detergent Tank	11 Liter	● سعة خزان المنظفات
● Pump Power	48 W	● قوة المضخة
● Pump Capacity	0,8 L/min	● سعة المضخة
● Pump Pressure	2 Bar	● ضغط المضخة

11014

GEC
Vaccums Series



مكنسة شفط مياه و اترية Wet And Dry Vaccum Cleaner GEC-POWERCLEAN

Sutable For **مناسبة**

AUTOMOTIVE	
HARDWARE CUSTOMER	
CONSTRUCTION	
LOGISTIC & TRANSPORT	
HEAVY INDUSTRY	



Technical details

المواصفات الفنية

● Number of motors	1 Motors	● عددالموتير
● Number of phases	1 Phase	● عدد المراحل
● Voltage/Frequency	60-50/220 V/Hz	● الجهد / التردد
● Power	1600 W	● قوة
● Tank Capacity	30 Liter	● سعة الخزان

11035

ماكينة بخار احترافية Professional Steam Machine SG-48

PORTOTECNICATM IPC Steamers Series

MADE IN ITALY



Suitable For مناسبة

AUTOMOTIVE	
RESTAURANT	
FOOD INDUSTRY AND RETAILERS	
LARGE COMMON AREAS	

Technical details

● Operating Pressure	0.8/8 Bar/Mpa
● Steam Flow Rate	80/100 G/min
● Steam Temperature (max)	(max) 185 °C
● Start Up Time	6 Min
● Power Supply	220 V
● Absorbed Power Max	3.5 kW
● Vacuum Power	1.4 kW
● Boiler Volume	3.4 kW
● Water Tank	3.2 L
● Detergent Tank	5 L



المواصفات الفنية

● ضغط التشغيل
● معدل تدفق البخار
● درجة حرارة البخار (الحد الأقصى)
● وقت البدء
● مزود الطاقة
● الطاقة الممتصة الفصوى
● قوة الفراغ
● حجم المرجل
● خزان المياه
● خزان المنظفات

12011

ماكينة بخار احترافية Professional Steam Machine SG-55

PORTOTECNICATM IPC Steamers Series

MADE IN ITALY



Suitable For مناسبة

AUTOMOTIVE	
RESTAURANT	
FOOD INDUSTRY AND RETAILERS	
LARGE COMMON AREAS	

Technical details

● Operating Pressure	0.8/8 Bar/Mpa
● Steam FlowRate	80/100 G/Min
● Steam Temperature (max)	(max) 185 °C
● Start Up Time	6 Min
● Power Supply	220 V
● Absorbed Power Max	3.5 kW
● Vacuum Power	10.4 kW
● Boiler Volume	1.4 kW
● Water Tank	4.2 L
● Detergent Tank	15 L



المواصفات الفنية

● ضغط التشغيل
● معدل تدفق البخار
● درجة حرارة البخار (الحد الأقصى)
● وقت البدء
● مزود الطاقة
● الطاقة الممتصة الفصوى
● قوة الفراغ
● حجم المرجل
● خزان المياه
● خزان المنظفات

120110

PORTOTECNICA
IPC
Steamers Series



مناسبة

AUTOMOTIVE	
RESTAURANT	
FOOD INDUSTRY AND RETAILERS	
LARGE COMMON AREAS	

ماكينة بخار احترافية
Professional Steam Machine
NEW STEAMY PLUS



Technical details

● Operating Pressure	0,5/5 Bar/Mpa
● Steam Flow Rate	0-100 g /min
● Max Steam Temperature	140 °C
● Start Up Time	7 Min
● Power Supply	220 V
● Max Absorbed Power	3 Kw
● Boiler Volume	2.2 L
● Water Tank	2 L

المواصفات الفنية

● ضغط التشغيل
● معدل تدفق البخار
● أقصى درجة حرارة للبخار
● وقت البدء
● مزود الطاقة
● أقصى قوة ممتصة
● حجم المرجل
● خزان المياه

120112

PORTOTECNICA
IPC
Steamers Series



Suitable For **مناسبة**

AUTOMOTIVE	
RESTAURANT	
FOOD INDUSTRY AND RETAILERS	
LARGE COMMON AREAS	

Technical details

● Operating Pressure	0,6/6 Bar/Mpa
● Steam Flow Rate	80+65 g /min
● Max Steam Temperature	165 °C
● Start Up Time	2.5 Min
● Power Supply	220 V
● Max Absorbed Power	3.2 Kw
● Boiler Volume	1.8 L
● Water Tank	2.5 L

ماكينة بخار احترافية
Professional Steam Machine
SG-10



المواصفات الفنية

● ضغط التشغيل
● معدل تدفق البخار
● أقصى درجة حرارة للبخار
● وقت البدء
● مزود الطاقة
● أقصى قوة ممتصة
● حجم المرجل
● خزان المياه

12012

ماكينة بخار احترافية Professional Steam Machine

ATS ELGI
THINK LONG RUN
Lifts Series



India
Made in India

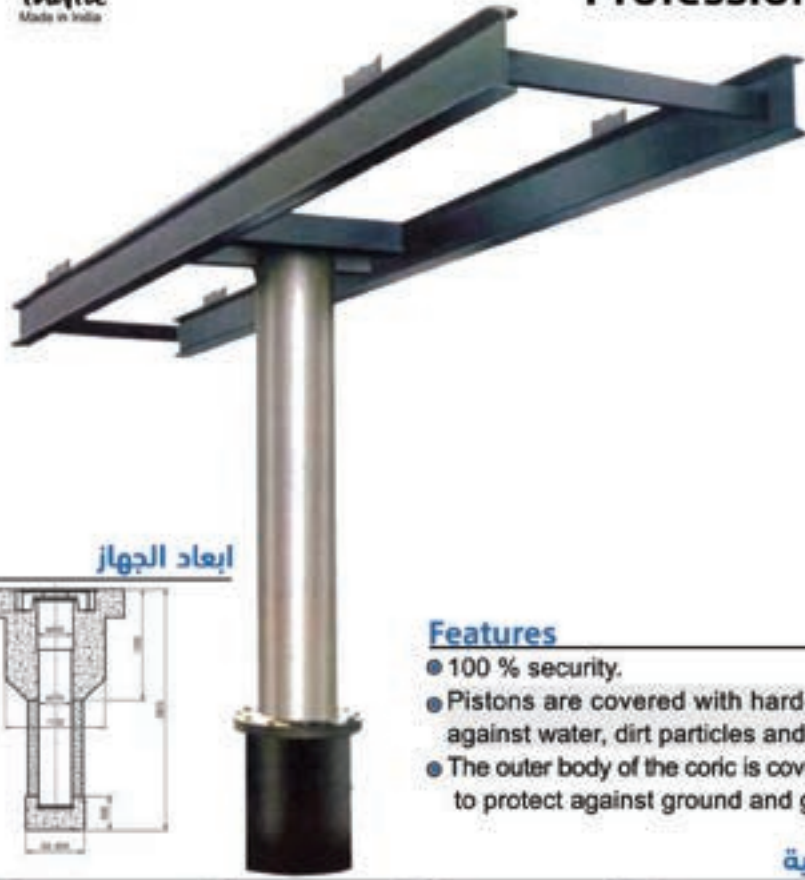

Line Draw

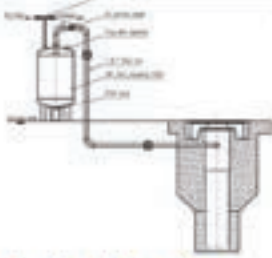

ابعاد الجهاز

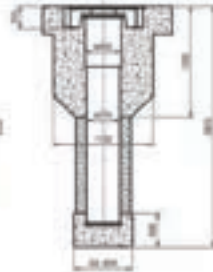

Features

- 100 % security.
- Pistons are covered with hardchrome to protect against water, dirt particles and clay.
- The outer body of the coric is covered with fiberglass to protect against ground and groundwater.

المميزات

Technical details

	4 Ton	4 Ton	8 Ton	8 Ton	المواصفات الفنية
● Lifting weight	4 Ton	4 Ton	8 Ton	8 Ton	● وزن الرفع
● Length of rails	450 Cm	450 Cm	450 Cm	450 Cm	● طول القضبان
● Max height	1520 Cm	1520 Cm	1520 Cm	1520 Cm	● أقصى ارتفاع
● Operating air pressure	8-10 Bar	8-10 Bar	8-10 Bar	8-10 Bar	● ضغط هواء التشغيل
● Tank Type	External	Internal	External	Internal	● نوع الخزان
	10012	10013	10014	10015	

GEC
GEC Tools Series

مطلع سيارة بلاستيك اسود هيفي ديوتي 2 قطعة Plastic car ramp reinforced



Technical details

- Plastic car starter reinforced
- Dimensions of one starter 22*31*92 Cm

المواصفات الفنية

- مطلع سيارة هيفي ديوتي بلاستيك مقوي
- أبعاد المطلع الواحد

10829



G.Foam Series



ماكينة فوم خزان محلي هيفي ديوتي Heavy Duty Local Tank Foam Machine

SST GEC / 70L



Technical details

● Material	Stainless Steel	● الهيكل
● Maximum Pressure	4 Bar	● أقصى ضغط
● Capacity	70 L	● السعة
● Tube Length	6 M	● طول الأنابيب
● Equipped With A Spray Gun		● مزودة بمسدس رش

1092



ماوسير مسدس غسيل High Pressure Lance



كفة مسدس غسيل High Pressure Washer Trigger



باي باص / منظم ضغط Brass Unloader Valve By-pass



A man in a dark blue polo shirt and black trousers is sitting on a green and black GEC floor cleaning machine. He is holding the steering wheel and looking forward. The machine has a large green seat and a black base with a brush. The background shows a factory floor with other machines and a red safety line.

حلول تنظيف الأرضيات

PORTOTECNICA MADE IN ITALY
Scrubber Series

عربة تنظيف وتجفيف الارضيات الصلبة
Compact Rider Floor Scrubber
Dryer 28 Inch
CT80-BT70



Suitable For **مناسبة**

- RETAIL
- RESTAURANT
- CLEANING CONTRACTORS
- MUNICIPALITIES



Technical details

● Max Theoretical Productivity	4070 M ³ /h
● Cleaning Path	700 Mm
● Water Tank Capacity (solution recovery)	W83/80 Liter
● Productivity For Shift	up to 3150 m ²
● Max Running Time	over 240 m ²
● Voltage	24(4x6)-180 V-Ah
● Installed Power	1600 W
● Brush Pressure	50 KG
● Squeegee Width	942 Mm
● Max Speed	6 Km/h

المواصفات الفنية

- أقصى إنتاجية نظرية
- مسار التنظيف
- سعة خزان المياه (استعادة المحلول)
- الإنتاجية من أجل التحول
- أقصى وقت تشغيل
- ضغط
- الطاقة المركبة
- ضغط الفرشاة
- عرض الممسحة
- السرعة القصوى

12017

PORTOTECNICA MADE IN ITALY
Scrubber Series

ماكينة تنظيف وتجفيف الارضيات الصلبة
Compact Automatic Floor
Scrubber Dryer 20 Inch
CT 40-B50



Suitable For **مناسبة**

- RETAIL
- RESTAURANT
- CLEANING CONTRACTORS
- MUNICIPALITIES



Technical details

Max Theoretical Productivity	m ³ /h 1750
Cleaning Path	500
Water Tank Capacity (Solution Recovery)	50/40
Max Running Time	Unlimitess
Voltage	220 V
Installed Power	1100 W
Brush Pressure	23 KG
Squeegee Width	815 Mm
Max Speed	3,5 Km/h

المواصفات الفنية

- أقصى إنتاجية نظرية
- مسار التنظيف
- سعة خزان المياه (استعادة المحلول)
- أقصى وقت تشغيل
- ضغط
- الطاقة المركبة
- ضغط الفرشاة
- عرض الممسحة
- السرعة القصوى

120125

PORTOTECNICATM
Scrubber Series

MADE IN ITALY

عربة تنظيف وتجفيف الارضيات الصلبة
iCompact Battery Floor Scrubber Dryer
11 Inch CYL 36V-LI-ION

TC 5B30



Suitable For مناسبة

RETAIL	
RESTAURANT	
CLEANING CONTRACTORS	
MUNICIPALITIES	

Technical details

● Max Theoretical Productivity	900 m ² /h
● Cleaning P.Tath	280 Mm
● Water Tank Capacity (solution recovery)	5 L
● Max Running Time	50/75 min
● Voltage	36 V-Ah
● Installed Power	220 W
● Brush Pressure	10 Kg
● Squeegee Width	300 Mm
● Max Speed	3 Km/h



المواصفات الفنية

● أقصى إنتاجية نظرية	900 م ² /س
● مسار التنظيف	280 مم
● سعة خزان المياه (استعادة المحلول)	5 لتر
● أقصى وقت تشغيل	50/75 دقيقة
● ضغط	10 كجم
● الطاقة المركبة	220 واط
● ضغط الفرشاة	10 كجم
● عرض الممسحة	300 مم
● السرعة القصوى	3 كم/س

12013

PORTOTECNICATM
Scrubber Series

ماكينة تنظيف وتجفيف
الارضيات الصلبة
High Pressure Lance
SD17HD



Technical details

● Working Width	430 Mm	● عرض العمل	430 مم
● Brush Speed	154 RPM	● سرعة الفرشاة	154 دورة/دقيقة
● Voltage	220 V	● ضغط	220 فولت
● Power	1300 W	● القدرة	1300 واط
● Brush Motor Rating	330 Mm	● تصنيف محرك الفرشاة	330 مم

12018

PORTOTECNICATM
Scrubber Series

ماكينة تنظيف وتجفيف
الارضيات الصلبة
High Pressure Lance
WEEPER550M



Technical details

● Side Brush Width	550 Mm	● عرض الفرشاة الجانبية	550 مم
● Max Productivity	1600 m ² /h	● أقصى إنتاجية	1600 م ² /س
● Tank Capacity	25 L	● سعة الخزان	25 لتر
● Max Speed	3,5 Km/h	● السرعة القصوى	3,5 كم/س
● Max Climb	2 %	● ماكس كلابمب	2 ٪

12019

A close-up photograph of a person's arm wearing a blue wristband and a grey work glove, adjusting a black tire on a red and silver tire machine. The tire is mounted on a silver alloy wheel. The background is a blurred workshop with a white car on a lift.

حلول مراكز الاطارات



Tire Changer Series

Line Draw

ابعاد المنتج

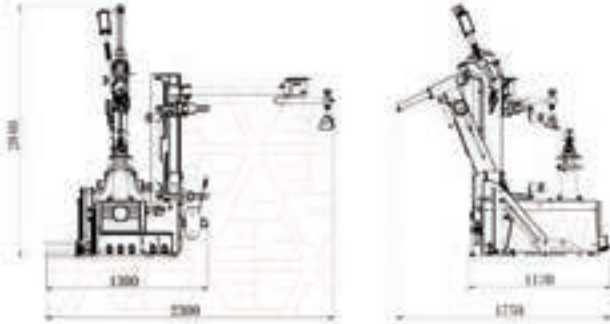

Highlights

المميزات

- Ergonomically machine body height.
- The horizontal swing arm is strengthened.
- Lock handle is strengthened.
- Modified bead breaking arm, breaking force increased by 30%.
- Strengthened machine body increased overall robustness.
- The silver alloy contactor on 40A switch to ensure it can bear large load, longevity.
- Optimized design of demounting head, greatly release the tire tension during demounting.

ماكينة فك و تركيب أوتوماتيك Automatic Tire Changer 897V



Technical details

المواصفات الفنية



901210



Tire Changer Series

Line Draw

ابعاد المنتج

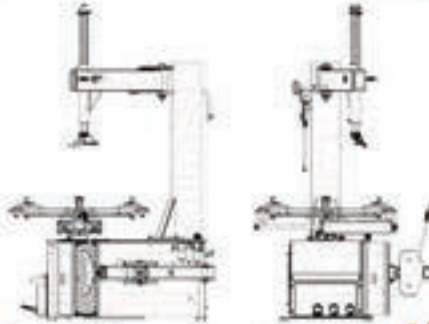

Highlights

المميزات

- Ergonomically machine body height.
- The horizontal swing arm is strengthened.
- Lock handle is strengthened.
- Modified bead breaking arm, breaking force increased by 30%.
- Strengthened machine body increased overall robustness.
- The silver alloy contactor on 40A switch to ensure it can bear large load, longevity.
- Optimized design of demounting head, greatly release the tire tension during demounting.

ماكينة فك و تركيب أوتوماتيك Automatic Tire Changer LC870N



Technical details

المواصفات الفنية

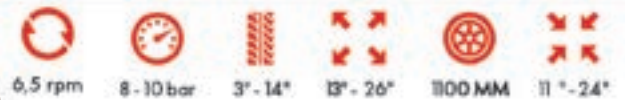

90123



Tire Changer Series

Line Draw

ابعاد المنتج

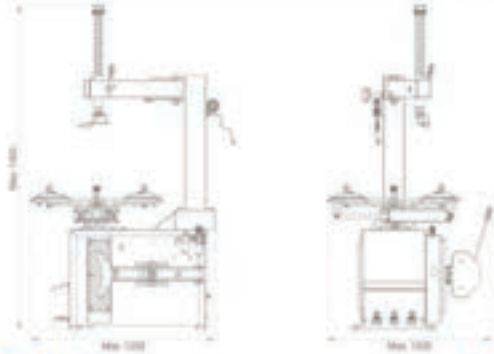

Highlights

- Ergonomically machine body height.
- The horizontal swing arm is strengthened.
- Lock handle is strengthened.
- Modified bead breaking arm, breaking force increased by 30%.
- Strengthened machine body increased overall robustness.
- The silver alloy contactor on 40A switch to ensure it can bear large load, longevity.
- Optimized design of demounting head, greatly release the tire tension during demounting.

المميزات

ماكينة فك و تركيب نصف أوماتيك Semi Automatic Tire Changer LC870N



Technical details

المواصفات الفنية

6,5 rpm	8 - 10 bar	3" - 14"	12" - 25"	1010* MM	10" - 22"

90122



Tire Changer Series

Line Draw

ابعاد المنتج

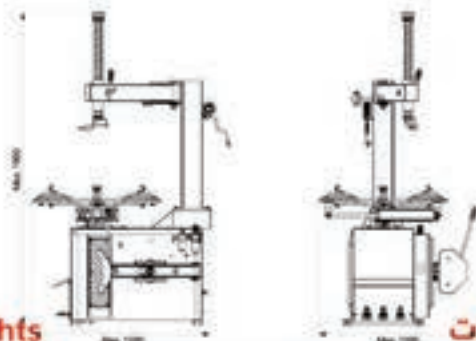

Highlights

- Ergonomically machine body height.
- The horizontal swing arm is strengthened.
- Lock handle is strengthened.
- Modified bead breaking arm, breaking force increased by 30%.
- Strengthened machine body increased overall robustness.
- The silver alloy contactor on 40A switch to ensure it can bear large load, longevity.
- Optimized design of demounting head, greatly release the tire tension during demounting.

المميزات

ماكينة فك و تركيب برايت نصف أوماتيك Semi Automatic Tire Changer LC807-24



Technical details

المواصفات الفنية

6,5 rpm	8 - 10 bar	3" - 12"	12" - 24"	960 MM	10" - 18"

90127



Wheel Balancer Series

Line Draw

ابعاد المنتج

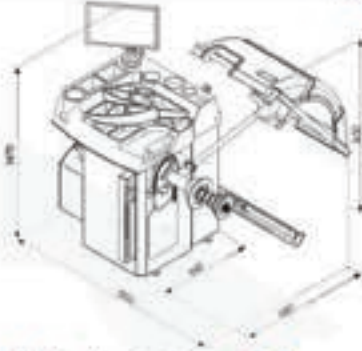

Highlights

Italian Software

المميزات

- CB 75P: Bright international brand triple layering machine, HAWEKA, German-made external accessories, SIEMENS, all internal components are German-made and Italian software.
- BT-X-100000 with a laser feature for higher accuracy.
- Equipped with a computer screen for stacking with highly advanced technology.
- LED light for easy operations

أوماتيك شاشة لمس كمبيوتر ثلاثي الابعاد Automatic With Touch Screen 3D CB78P



Technical details

المواصفات الفنية



50219



Wheel Balancer Series

Line Draw

ابعاد المنتج



Highlights

Italian Software

المميزات

- The machine has an easy-to-use Italian program.
- Automatic calculation of diameter and distance.
- The machine has 5 ALU balancing programs and 2 intelligent ALU balancing programs.
- The machine is equipped with a 19-inch LCD screen.
- The device will enter standby mode when not in use for a certain period.
- Weight position position at six o'clock, with laser signal line, fast and comfortable.

أوماتيك بشاشة كمبيوتر بالسونار Automatic With Sonar Gauge CB75-S



Technical details

المواصفات الفنية



50211



Wheel Balancer Series

Line Draw

ابعاد المنتج

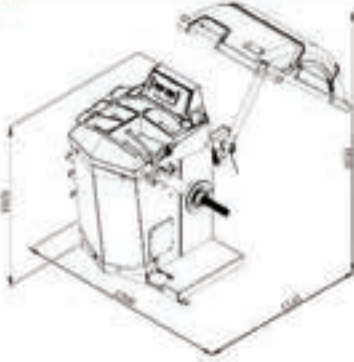

Highlights

المميزات

- The balancer has independent intellectual property rights. The balancer has DYN/STA and different ALU balancing programs, this balancer also has motorcycle balancing program.
- The machine allows user to customize settings.
- The calibration is easy to proceed, the machine can quickly get back its precision.
- The balancing shaft is suitable for wider wheels.

50218

أوماتيك بسوفت وير ايطالي Automatic With Italian Software CB3020



Technical details

المواصفات الفنية



Wheel Balancer Series

Line Draw

ابعاد المنتج



Highlights

المميزات

- The balancer has independent intellectual property rights. The balancer has DYN/STA and different ALU balancing programs, this balancer also has motorcycle balancing program.
- The machine allows user to customize settings.
- The calibration is easy to proceed, the machine can quickly get back its precision.
- The balancing shaft is suitable for wider wheels.

50217

أوماتيك بسوفت وير ايطالي Automatic With Italian Software CB3010



Technical details

المواصفات الفنية





Wheel Balancer Series

Line Draw

ابعاد المنتج



Highlights

المميزات

- The balancer has independent intellectual property rights.
- The balancer has DYNSTA and different ALU balancing programs, this balancer also has motorcycle balancing program.
- The machine allows user to customize settings, for example, switch on/off protective cover, display fine imbalance, etc.
- Customer can input distance/diameter/width by clockwise/anti-clockwise wheel rotation.
- The calibration is easy to proceed, the machine can quickly get back its precision.

50214

جهاز ترصيص ملاكي رقمي /ديجيتال Automatic Wheel Balancer CB953GB



Technical details

المواصفات الفنية

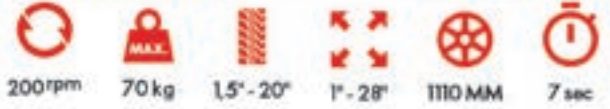

Wheel Balancer Series

Line Draw

ابعاد المنتج

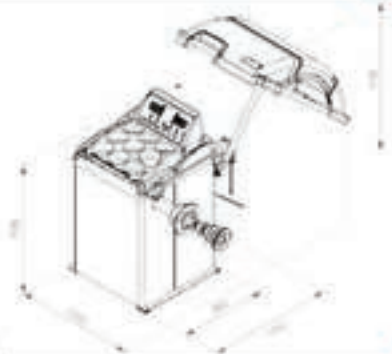

Highlights

المميزات

- The balancer has independent intellectual property rights.
- The balancer has DYNSTA and different ALU balancing programs, this balancer also has motorcycle balancing program.
- The machine allows user to customize settings, for example, switch on/off protective cover, display fine imbalance, etc.
- Customer can input distance/diameter/width by clockwise/anti-clockwise wheel rotation.
- The calibration is easy to proceed, the machine can quickly get back its precision.

50213

جهاز ترصيص ملاكي رقمي /ديجيتال Automatic Wheel Balancer CB910GBS



Technical details

المواصفات الفنية





Wheel Balancer Series

Line Draw

ابعاد المنتج

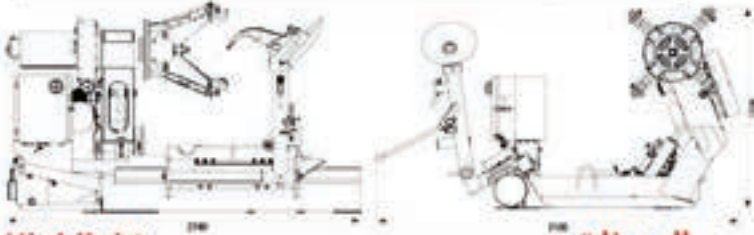

Highlights

- Adopted hydraulic control system, reliable rim clamping, move stable. Hydraulic pump station adopted imported components with good stability .
- Meet CE requirement, totally safe during operation.
- Lifting arm cylinder is center supported , bear pressure average.
- Movable operating station can be fully observed during operation to prevent danger by misoperation.
- The gearbox is made of aluminum alloy die casting, with light weight, beautiful appearance, high intensity and good sealing performance.
- The electric cabinet adopted CE level protection standard.
- Lifting arm and the base are made of strengthened and thickened metal, with high intensity.

المميزات

ماكينة فك وتركيب برايت نقل حتى
جنط 26 بوصة 3 فاز

Automatic Truck 26 Inch Rim
LC588S



Technical details

المواصفات الفنية



26"



560 kg



1000 MM



1500 MM

90128



Wheel Balancer Series

Line Draw

ابعاد المنتج

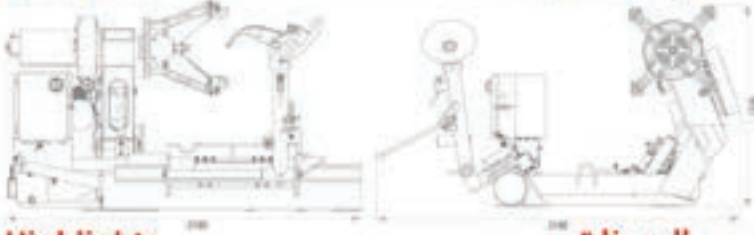

Highlights

- Hydraulic system with imported components for superior performance.
- Supports rim diameters from 14" to 46" (up to 56" with an extension).
- Powerful hydraulic pressure (130-150 bar) for efficient tire changing.
- Lightweight yet durable aluminum alloy gearbox for high-intensity performance.
- Low-noise operation (<75dB) for a better working environment.
- CE-certified for safety and reliability.

المميزات

ماكينة فك وتركيب اورلانديني
ايطالي نقل 56 بوصة 3 فاز

ORLANDINI Automatic Truck
Tire Changer 56 Inch Rim
590D



Technical details

المواصفات الفنية



46"



1100MM



891kg



2200MM

90129

BRIGHT

HWN Series

منفاخ الإطارات بالنتروجين

Nitrogen Tire Inflator



HWN-90



HWN-80



HWN60

Technical details

Model	HNW-90	HNW-80	HNW-60	موديل
Working Temperature Range	20—70°C	20—70°C	20—70°C	نطاق درجة حرارة العمل
Power Supply	220V Hz	220V Hz	220V Hz	مصدر الطاقة
Power	120 W	30 W	30 W	الطاقة
Inlet Pressure	10-15 Bar	6-10 Bar	6-10 Bar	ضغط المدخل
Nitrogen Output pressure	10-12 Bar	6-8 Bar	6-8 Bar	ضغط إخراج النيتروجين
Nitrogen purity	95% : %99.5	95% : %99.5	95% : %99.5	نقاء النيتروجين
Nitrogen Storage Tank Capacity	160 L	80 L	60 L	سعة خزان النيتروجين

801414

801413

801412

المواصفات الفنية

GEC مسدس تزويد كاوتش
Tire Inflators



804322

GEC مسدس تزويد كاوتش
Tire Inflators



804330

GEC قائم تزويد كاوتش
Tire Inflators



80172

GEC مسدس تزويد
كاوتش ديجيتال
Tire Inflators



8043210

GEC
Tire Inflators

قائم تزويد كاوتش ديجيتال
ملاكي و نقل
Automatic Digital Tire
Inflator With Stand

HWP-110



Features

- It supplies automatically according to the selected program.
- Equipped with a special program in case of completely empty tires.
- Equipped with a special air inlet to reduce noise.

Technical details

- Temperature Range 20 - 70°C نطاق درجة الحرارة
- Power Source 220 V مصدر الطاقة
- Power 10 W الطاقة
- Max Pressure 12 Bar أقصى ضغط
- Precision P±0.007 Bar الدقة
- Pressure Unit PSI/bar/Kpa/kg/cm² وحدة الضغط

80171



Vulca Series



M10



P20



P40

مكاوي لحم كاوتش بالهواء Tyres Vulcanizers

Technical details

Model	M10	P10	P40	موديل
Power	600 W	250 W	1200 W	القدرة
Electricity	220 V	220 V	220 V	الكهرباء
Frequency	50Hz-60Hz	50Hz-60Hz	50Hz-60Hz	التردد
Pressure	-	10 Bar	10 Bar	ضغط الهواء
Temperature	135°C	135°C	135°C	درجة الحرارة
Net weight	7,55 kg	13 kg	29,4 kg	الوزن الصافي
Heating Unit Size	19x10 cm	ø7 cm	19x10 cm	حجم وحدة التسخين

15011

15013

15012

المواصفات الفنية



Vulca Series



GEC-NK56



GEC-MK2591



GEC-MK2887

مكاوي لحم كاوتش Tyres Vulcanizers

Technical details

Model	GEC-NK 56	GEC-MK2591	GEC-2887	موديل
Power	500 W	450 W	450 W	القدرة
Electricity	220 V	220 V	220 V	الكهرباء
Frequency	50Hz-60Hz	50Hz-60Hz	50Hz-60Hz	التردد
Pressure	10 Bar	10 Bar	10 Bar	ضغط الهواء
Temperature	145°C : 165°C	155°C : 165°C	140°C : 165°C	درجة الحرارة
Heating Unit Size	8*10 cm	8 cm	8 cm	حجم وحدة التسخين

105210

15024

15022

المواصفات الفنية

ونش ظرافة مفصلي Engine Crane

GEC Hydraulic Series



GEC-EC1T



GEC-EC2T



GEC-EC3T

Technical details

Model	GEC-CL1T	GEC-CL2T	GEC-CL3T	موديل
Lift Capacity	1 Ton	2 Ton	3 Ton	الحمولة
Lifting Height	2450 mm	2250 mm	2000 mm	اقصى ارتفاع
Weight	75 Kg	83 Kg	136 Kg	الوزن

10035

100313

100311

المواصفات الفنية

GEC Hydraulic Series



GEC-HJS1

كوريك فتييس شمعة Hydraulic Jack Stand



GEC-HJS1/2

Technical details

Model	GEC-HJS1	GEC-HJS1/2	موديل
Lift Capacity	1 Ton	1/2 Ton	الحمولة
Max Height	1850 mm	1900 mm	اقصى ارتفاع
Min Height	1100 kg	860 kg	اقل ارتفاع

10033

100310

المواصفات الفنية

GEC Hydraulic Series

زرجينة سوست مساعدين Hydraulic Strut Spring Compressor GEC-SSC1



Technical details

Model	GEC-SSC1	موديل
Capacity	1 Ton	الحمولة
Compressing Area	57- 21 mm	مساحة اللفظ
Spring Size	400 mm	طول السوستة مضغوطة

10032

المواصفات الفنية



Hydraulic Series

مكبس هيدروليكي Hydraulic Press



GEC-HP10



GEC-HP20

GEC-HP30

GEC-HP50

Technical details

المواصفات الفنية

Model	GEC-HP10	GEC-HP20	GEC-HP30	GEC-HP50	موديل
Capacity	10 Ton	20 Ton	30 Ton	50 Ton	القدرة
Working Range	370- 330mm	1020-490 mm	1030-0 mm	1040-650 mm	نطاق العمل
Stroke	150 mm	170 mm	150 mm	190 mm	الحد الأقصى للمشوار
Packing Size	15*52*75 cm	24*23*156 cm	27*78*192 cm	190*93*34 cm	حجم العبوة

170159

100319

1003105

1003106



Hydraulic Series

مكبس هيدروليكي Hydraulic Bottle jack



GEC-HBJ5



GEC-HBJ10



GEC-HBJ20



GEC-HBJ32



GEC-HBJ50

Technical details

المواصفات الفنية

Model	GEC- HBJ5	GEC- HBJ10	GEC-HBJ20	GEC-HBJ32	GEC-HBJ50	موديل
Lifting Weight	5 Ton	10 Ton	20 Ton	32 Ton	50 Ton	وزن الرفع
Min. Height	200 mm	205 mm	225 mm	285 mm	300 mm	الحد الأدنى للارتفاع
Max. Height	385 mm	390 mm	425 mm	465 mm	480 mm	الحد الأقصى للارتفاع
Packing Size	62*14*22.5 cm	64.5*14.5*22.5 cm	24.5*19*34 cm	37*19.5*29.5 cm	21*18*27 cm	الابعاد

1002124

10021117

10021114

10021121

10021122



Hydraulic Series

مكابس هيدروليكية Hydraulic Press



Technical details

Model	T83002	T830025	T070203	T070110	موديل
Lifting Weight	3 Ton	3 Ton	3 Ton	2.5 Ton	وزن الرفع
Min. Height	135 mm	135 mm	135 mm	75 mm	الحد الأدنى للارتفاع
Max. Height	495 mm	500 mm	495 mm	500 mm	الحد الأقصى للارتفاع
Packing Size	20*37*68 cm	20*37*68 cm	20*39* 70 cm	1 15*34* 74 cm	الابعاد

100214

10021118

100211

100217

Model	TRA3813	TR50001	TR30001	T2B20031	موديل
Lifting Weight	2 Ton	5 Ton	3 Ton	3.5Ton	وزن الرفع
Min. Height	200 mm	150 mm	140 mm	105 mm	الحد الأدنى للارتفاع
Max. Height	560 mm	600 mm	620 mm	525 mm	الحد الأقصى للارتفاع
Packing Size	20*28*48 cm	21*28*150 cm	22*39* 148cm	20*46*87 cm	الابعاد

10021119

100213

100212

10021115



• Foot Pedal



• 2 Pistons



• 2 Strong Handel

مسدس حل وربط صيني Impact Wrenches

AEROPRO
ENGINEERED FOR PROFESSIONALS
AP Series



Technical details

Model	AP7488	AP7462	AP7424	AP17808	موديل
• Square Drive	1 Inch	3/4 inch	1/2 Inch	1/2 Inch	• محرك مربع
• Speed	3600 RPM	4600 RPM	7500 RPM	7500 RPM	• سرعة
• Torque	3100 N	1600 N	610 N	610 N	• عزم الدوران
• Air Hose Type	5/8 Inch	3/8 Inch	3/8 Inch	3/8 Inch	• نوع خرطوم الهواء
• Average Air Consumption	1140 L/min	143.9 L/min	183.9 L/min	183.9 L/min	• متوسط استهلاك الهواء
• Weight	16.3 kg	7 kg	2.1 kg	2.1 kg	• وزن
• Length	58.6 cm	25.3 cm	18.5 cm	18.5 cm	• طول
	80427	804211	804215	8042321	

المواصفات الفنية

AEROPRO
ENGINEERED FOR PROFESSIONALS
AP Series

صاروخ هواء 5 لفات
Air Angle Sander
AP319



Technical details

• Model	AP7319	• موديل
• Speed	1000 rpm	• سرعة
• Air Hose Type	3/8 Inch	• نوع خرطوم الهواء
• Avr. Air Consump.	141.7 L/min	• متوسط استهلاك الهواء
• Weight	1.92 Kg	• وزن

1303311

AEROPRO
ENGINEERED FOR PROFESSIONALS
AP Series

بافر صنفرة دائري 5 بوصة
Air Sander
AP7335



Technical details

• Model	AP7335	• موديل
• Reduce	5 Inchs	• القطر
• Speed	1000 RPM	• سرعة
• Air Hose Type	3/8 Inch	• نوع خرطوم الهواء
• Avr. Air Consump.	128.2 L/min	• متوسط استهلاك الهواء
• Weight	1.08 kg	• وزن

130369

شنيور هواء بيد جانبية Keyless Air Drill AP7462

AEROPRO ENGINEERED FOR PROFESSIONALS AP Series



Technical details

● Model	AP1780B
● Cover	1/2 Inch
● Speed	700 RPM
● Air Hose Type	3/8 Inch
● Weight	1.4 Kg
● Length	19.5 cm

المواصفات الفنية

● Model	AP1780B	● موديل
● Cover	1/2 Inch	● محرك مربع
● Speed	700 RPM	● سرعة
● Air Hose Type	3/8 Inch	● نوع خرطوم الهواء
● Weight	1.4 Kg	● وزن
● Length	19.5 cm	● طول

8042321

AEROPRO ENGINEERED FOR PROFESSIONALS AP Series AP27313K

صاروخ اسطمبات بالهواء Air Molding Polisher



11 Pieces

8042321

AEROPRO ENGINEERED FOR PROFESSIONALS AP Series AP17813

صاروخ اسطمبات بالهواء Air Molding Polisher



16 Pieces

8042321

AEROPRO ENGINEERED FOR PROFESSIONALS AP Series AP8036

صاروخ اسطمبات بالهواء Air Molding Polisher



8042321

AEROPRO ENGINEERED FOR PROFESSIONALS AP Series R8043

صاروخ اسطمبات بالهواء Air Molding Polisher



8042321



حلول

مراكز الزوايا

BRIGHT 
ALPHA Series

جهاز ضبط زوايا ثلاثي الابعاد ذراع متحرك اوتوماتيك Wheel Alignment Machine 3D A750

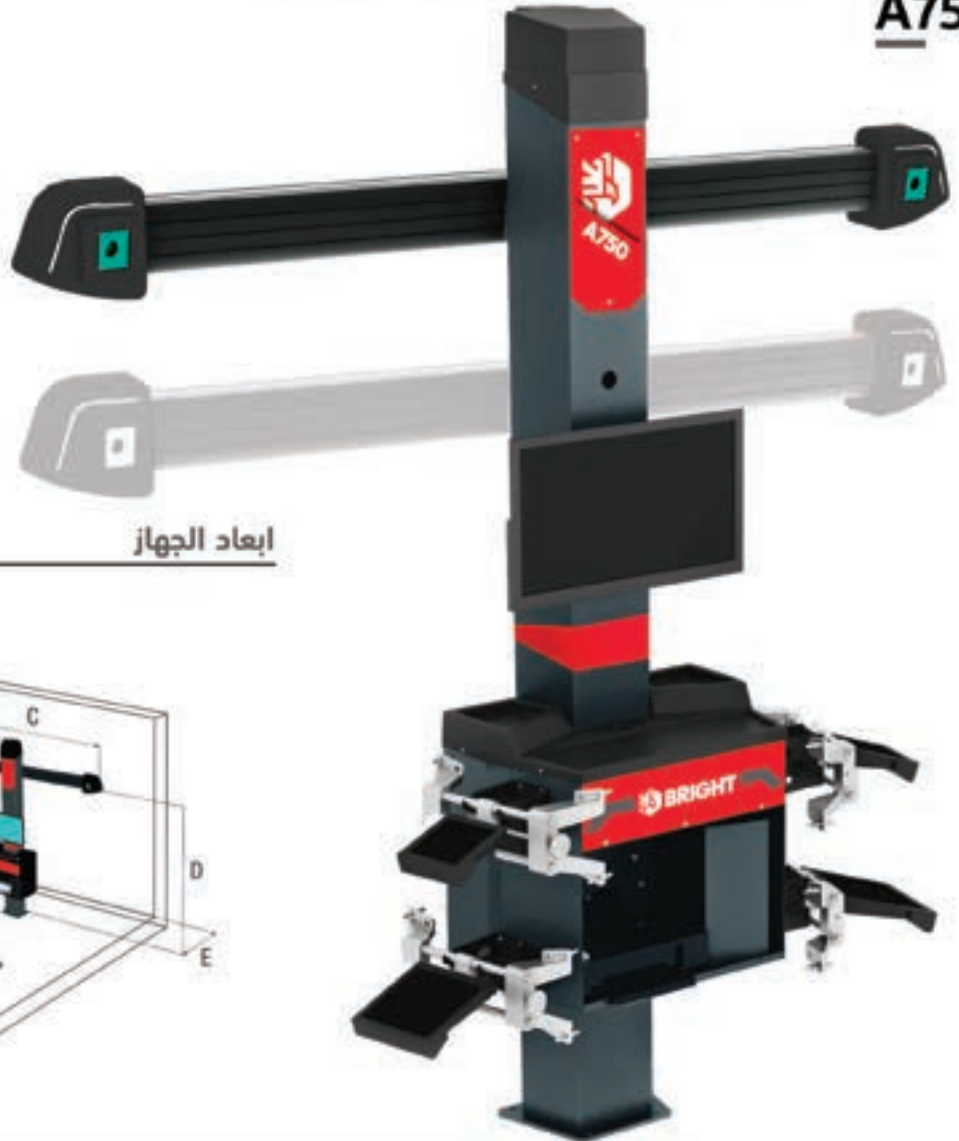

Line Draw

ابعاد الجهاز

A = Min. 1800 - Max 3000 mm
B = 2918 mm
C = 2878 mm
D = Work from 500 to 2560 mm
E = Min. 400 mm

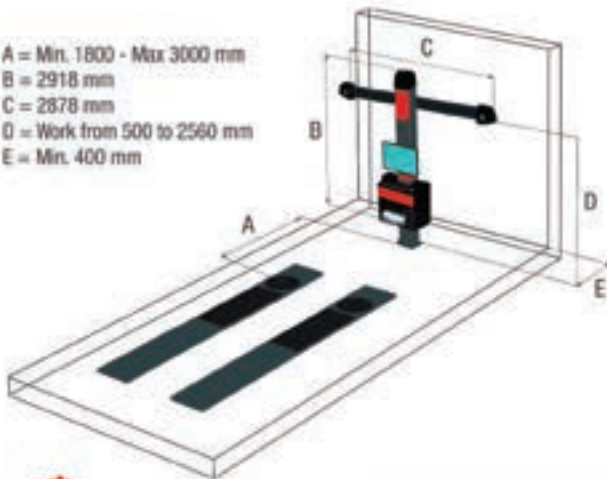

A750

مناسب



غير مناسب



يوفي الغرض



Features

- The tracking camera beam can also be manually operated on the keyboard.
- Easy-to-use software with Italian design.
High-definition cameras work in multiple lighting conditions including direct sunlight. 10 million pixels HD.
- High-resolution, anti-glare targets filtered to work with UV rays.
- Self-centering H-shaped clamps.
- 10-inch - 26-inch wheels.
- Factory calibrated and no need for maintenance calibration.
- Alignment data for over 60,000 vehicle models.

المميزات

Measuring ranges

Measuring ranges		نطاقات القياس
● Total toe	± 20°	Total toe ●
● Half toe	± 10°	Half toe ●
● Camber	± 10°	الحدبة ●
● Caster	± 30°	العجلات ●
● Kingpin	± 30°	King pin ●
● Set back	± 22°	الارتداد ●
● Thrust angle	± 10°	زاوية الدفع ●
● Steering difference	± 20°	فرق التوجيه ●

6011

BRIGHT 
ALPHA Series

جهاز ضبط زوايا ثلاثي الابعاد ذراع متحرك اوتوماتيك Wheel Alignment Machine 3D A730E

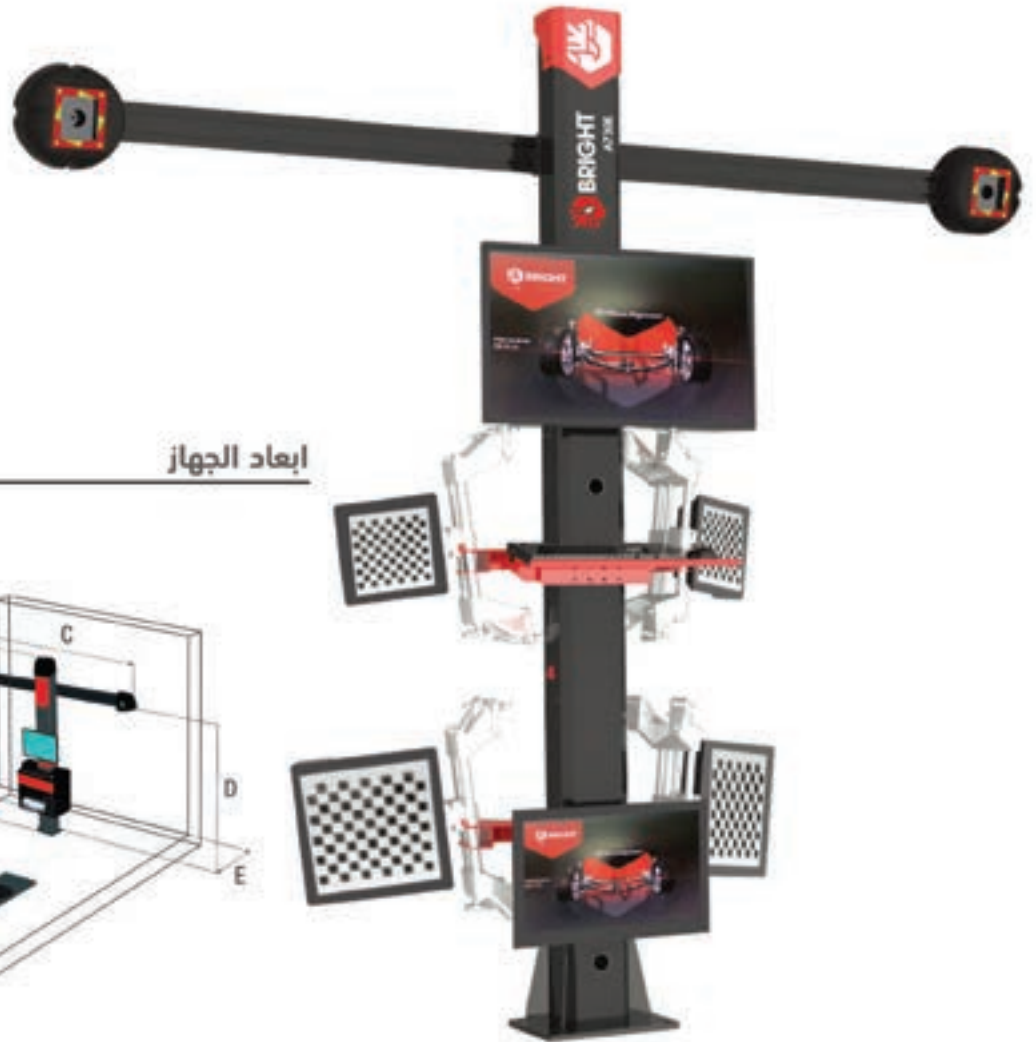

Line Draw

ابعاد الجهاز

A = Min. 1800 - Max 3000 mm
B = 2918 mm
C = 2878 mm
D = Work from 500 to 2560 mm
E = Min. 400 mm

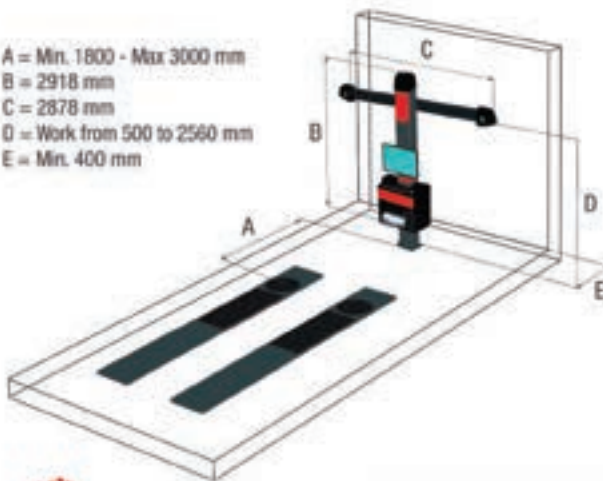

A730E



مناسب



غير مناسب



يوفي الغرض



Features

- The tracking camera beam can also be manually operated on the keyboard.
- Easy-to-use software with Italian design.
High-definition cameras work in multiple lighting conditions including direct sunlight. 10 million pixels HD.
- High-resolution, anti-glare targets filtered to work with UV rays.
- Self-centering H-shaped clamps.
- 10-inch - 26-inch wheels.
- Factory calibrated and no need for maintenance calibration.
- Alignment data for over 60,000 vehicle models.

المميزات

Measuring ranges

Measuring ranges		نطاقات القياس
● Total Toe	± 48°	Total toe ●
● Half Toe	± 26°	Half toe ●
● Camber	± 20°	الحدبة ●
● Caster	± 30°	العجلات ●
● Kingpin	± 30°	King pin ●
● Set Back	± 25°	الارتداد ●
● Thrust Angle	± 15°	زاوية الدفع ●

6012

BRIGHT 
KAPPA Series

كوريك 4 عمود 5 طن مجهز زوايا / قفل يدوي
5 Ton 4-Post Alignment Lift
KAPPA500



5000 KG

Line Draw

ابعاد الجهاز

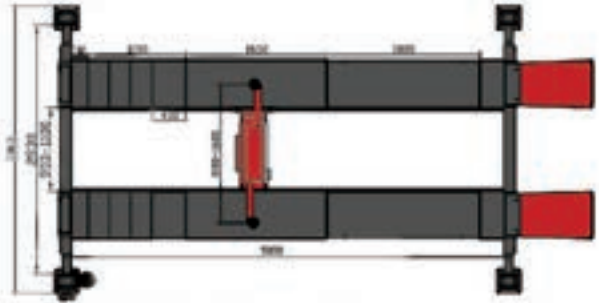

KAPPA500



مناسب



غير مناسب



يوفي العرض



Features

- Pneumatic opening design, 4-point locking system, can adjust the landing speed.
- Steel rope breakage protection device, safe operation.
The runway distance can be adjusted to suit vehicles of wider width Different wheels.
- Equipped with a variety of spacer blocks for different sizes
- Wheelbases and turntables.
- A lifting beam is optionally provided, and the lifting beam does the lifting
- 24V safe operation control system.
- Approved by %115 dynamic load test.
and %150 static load test.

المميزات

Technical details

- Lifting Capacity 5000 kg قدرة الرفع
- Lifting Height 245 mm - 1800 mm ارتفاع الرفع
- Jacking Beam Height 450 mm- 500 mm ارتفاع شعاع الرفع
- Jacking Beam Capacity 3000 kg قدرة شعاع الرفع
- Air Pressure 6-8 Bar ضغط الهواء

الموصفات الفنية

100552



كوريك 2 عمود برايت 4 طن وصلة سفلية 4 Ton Baseplate 2-Post Lift 40E

4000 | KG

Line Draw أبعاد الجهاز

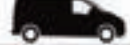

40E



مناسب



غير مناسب



يوفي العرض



Features

- The shaft is equipped with 5mm steel plate to ensure strength, 16mm diameter column bottom plate to ensure foundation
- stability.
High strength trolley design, total plate curvature 14mm.
Lifting arm with reinforced design, prevent deformation.
- Fitted with foot handrails as standard.
- Equipped with a height limit Microswitch as standard.
- High-strength fine tooth locking mechanism, interlocks more closely.
- The height of the ground connection plate is only 28mm, making it
- convenient for maintenance. With 115mm diameter steel rope pulley, prevent the steel rope from being abraded, for smoother running.

المميزات

Technical details

الموصفات الفنية	Technical details	الموصفات الفنية
● قدرة الرفع	● Lifting Capacity 4000 kg	● قدرة الرفع
● وقت الرفع	● Lift Time 40 sec	● وقت الرفع
● ارتفاع الرفع	● Lift Height 1900 mm	● ارتفاع الرفع
● الحد الأدنى الارتفاع	● Minimum Height 98 mm	● الحد الأدنى الارتفاع
● الارتفاع الإجمالي	● Overall Height 2830 mm	● الارتفاع الإجمالي
● مسافة العمود	● Post Distance 2800 mm	● مسافة العمود
● العرض الإجمالي	● Overall Width 3350 mm	● العرض الإجمالي
● قوة الموتر	● Motor Power 2.2 kw	● قوة الموتر
● مدخلات الطاقة	● Power Input 380 V	● مدخلات الطاقة

100551

BRIGHT
BETA Series



كوريك 2 عمود براييت 4 طن وصلة علوية 4 Ton Overhead 2-Post Lift 40BE

4000 | KG

Line Draw

ابعاد الجهاز

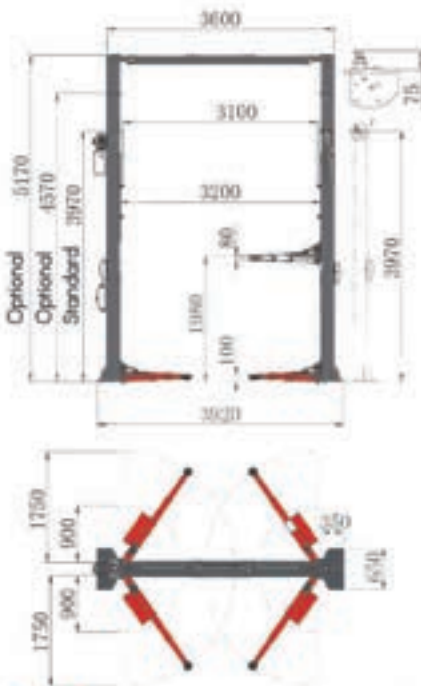

40BE

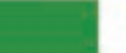
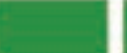
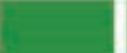
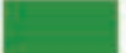

مناسب



غير مناسب



يوفي العرض



Features

- The shaft is equipped with 5mm steel plate to ensure strength, 16mm diameter column bottom plate to ensure foundation stability.
- High strength trolley design, total plate curvature 14mm. Lifting arm with reinforced design, prevent deformation.
- Fitted with foot handrails as standard.
- Equipped with a height limit Microswitch as standard.
- High-strength fine tooth locking mechanism, interlocks more closely.
- The height of the ground connection plate is only 28mm, making it convenient for maintenance. With 115mm diameter steel rope pulley, prevent the steel rope from being abraded, for smoother running.

المميزات

Technical details

- | المواصفات الفنية | Technical details | المواصفات الفنية |
|------------------------|---------------------------|------------------------|
| ● قدرة الرفع | ● Lifting capacity 4000KG | ● قدرة الرفع |
| ● وقت الرفع | ● Lift time 40s | ● وقت الرفع |
| ● ارتفاع الرفع | ● Lift Height 1900mm | ● ارتفاع الرفع |
| ● الحد الأدنى للارتفاع | ● Minimum Height 98mm | ● الحد الأدنى للارتفاع |
| ● الارتفاع الإجمالي | ● Overall Height 2830mm | ● الارتفاع الإجمالي |
| ● مسافة العمود | ● Post Distance 2800mm | ● مسافة العمود |
| ● العرض الإجمالي | ● Overall Width 3350mm | ● العرض الإجمالي |
| ● قوة الموتر | ● Motor Power 2.2KW | ● قوة الموتر |
| ● مدخلات الطاقة | ● Power Input 220V/380V | ● مدخلات الطاقة |

100553



كوريك مقص 3 طن ارتفاع منخفض 3 Ton Low-Profile Scissor Lift OMEGA300E

3000 | KG



Line Draw

إبعاد الجهاز

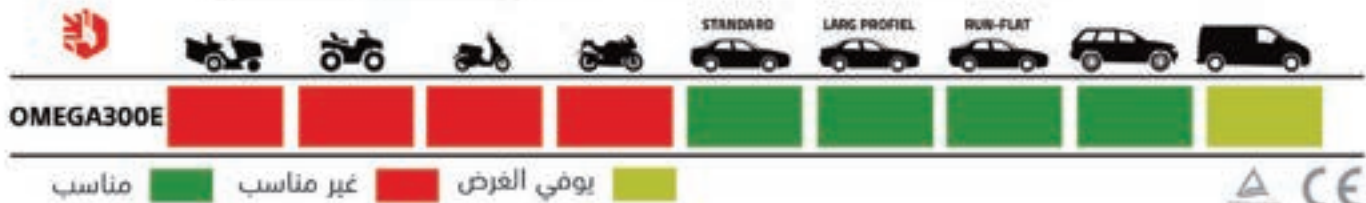
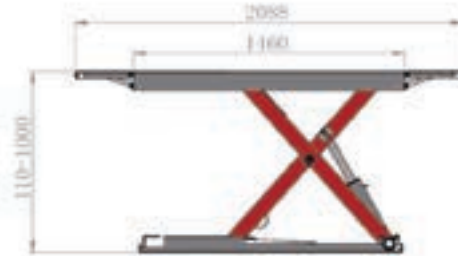
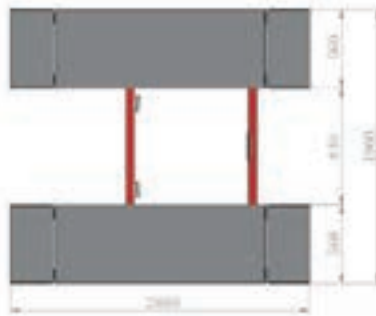

Features

- Pneumatic opening design, 4-point locking system, can adjust the landing speed.
- Steel rope breakage protection device, safe operation.
The runway distance can be adjusted to suit vehicles of wider width
Different wheels.
- Equipped with a variety of spacer blocks for different sizes
- Wheelbases and turntables.
- A lifting beam is optionally provided, and the lifting beam does the lifting
- 24V safe operation control system.
- Approved by %115 dynamic load test
and %150 static load test.

المميزات

Technical details

- قدرة الرفع 3000kg
- وقت الرفع 40s
- ارتفاع الرفع 1000mm
- الحد الأدنى الارتفاع 110mm
- الارتفاع الإجمالي 1460mm
- مسافة العمود 560mm
- العرض الإجمالي 1960mm
- قوة الماتور 2.2kW
- مدخلات الطاقة 220V/380V

الموصفات الفنية

100554

BRIGHT 
SIGMA Series

كوريك مقص طن شديد الارتفاع 3 طن
3 Ton Ultra-Thin Scissor Lift
SIGMA300E

3000 | **KG**



Line Draw

إبعاد الجهاز

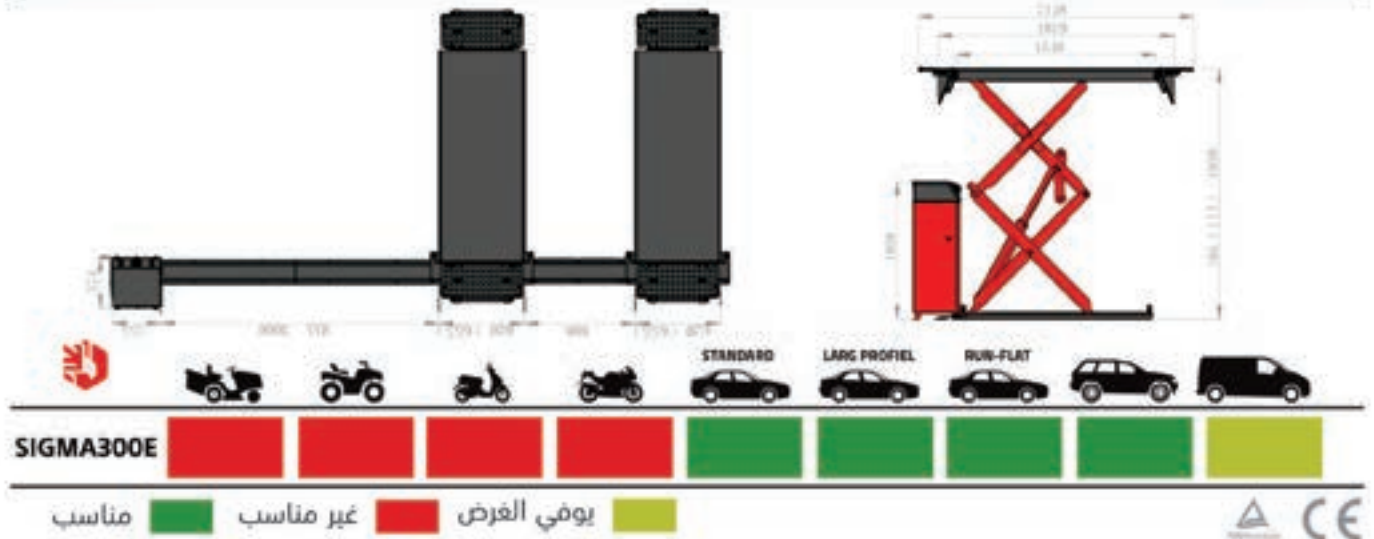

Features

- Pneumatic opening design, 4-point locking system, can adjust the landing speed.
- Steel rope breakage protection device, safe operation.
The runway distance can be adjusted to suit vehicles of wider width Different wheels.
- Equipped with a variety of spacer blocks for different sizes
- Wheelbases and turntables.
- A lifting beam is optionally provided, and the lifting beam does the lifting
- 24V safe operation control system.
- Approved by %115 dynamic load test and %150 static load test.

المميزات

Technical details

- قدرة الرفع 3000 kg
- وقت الرفع 45 s
- ارتفاع الرفع 1930 mm
- الحد الأدنى للارتفاع 105 mm
- الارتفاع الإجمالي 1460mm
- طول المنصة 1540 mm-2130 mm
- عرض المنصة 620 mm
- تباعد المنصة 808 mm
- قوة الموتر 2.2 kW
- مصدر الطاقة 220V/380V

الموصفات الفنية

100555



GEC Lifts

2500 KG



كوريك مقص منتصف السيارة 2.5 طن متحرك GEC Pneumatic Scissor Lift TJSAD-91625



Product Usage

استخدام المنتج



Line Draw

إبعاد الجهاز

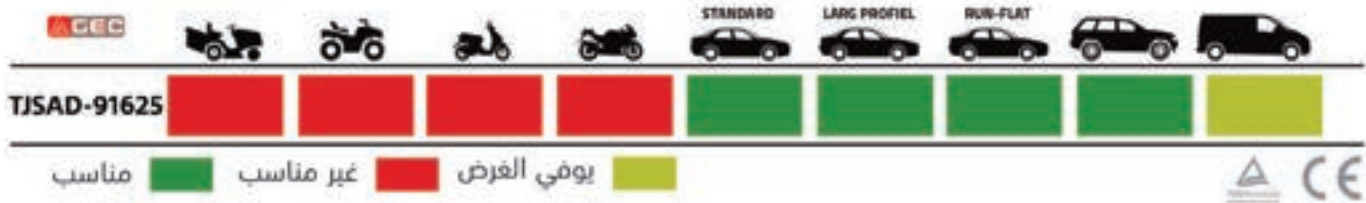
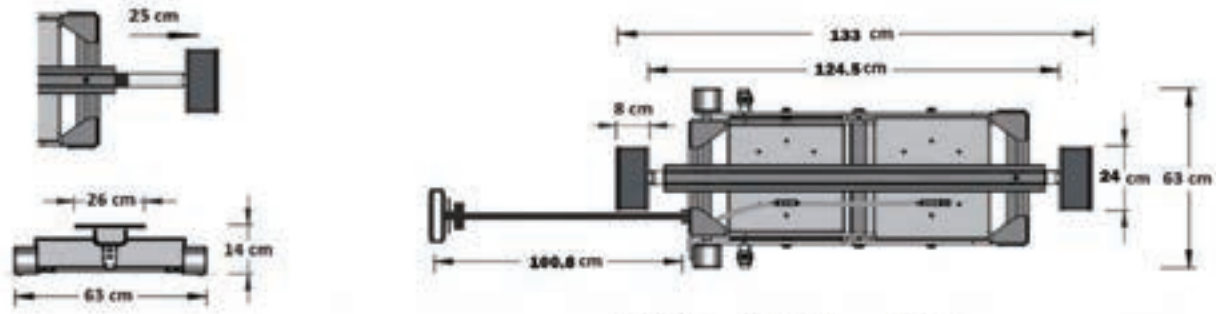

Features

- All-in-one controller at the end of the handle.
- The mini lift can be moved, maneuvered, raised and lowered using the handle.
- The handle is swingable and can be folded both ways.
- The handle is also foldable for use in tight spaces.
- Completely pneumatic, using two heavy duty shafts 63cm wide base for optimal stability.
- The telescopic arms have an index of 7 cm and are both limited to 27.5 cm.

المميزات

Technical details

الموصافات الفنية

- القدرة 2.5 tons
- الحد الأدنى للارتفاع 138mm
- الحد الأقصى للارتفاع 550 mm
- الارتفاع 1500 mm
- حجم المنتج 630+1300 mm

100553

LAUNCH® X-431 Series

جهاز تشخيص و كشف اعطال Multi-System Diagnostic & Service Tool X-431 PRO3



Features

- Enables you to diagnose light, medium & heavy duty (optional) vehicles with Smartlink C.
- Full system vehicle coverage for U.S., Asian and European markets over 110 manufacturers, which is continually updated.
- Real-time voltage display is supported, which helps you monitor the voltage condition of the vehicle during the diagnosis.
- Intelligent diagnostic enables automatic VIN identity to automatically access systems quickly.
- Intelligent and local diagnostic, which include full diagnostic functions, such as read/clear DTC, live data streaming, bi-directional control, coding, etc.
- Guided functions for VW and AUDI. (Support a total of over 30,000 functions for VW and AUDI)
- Optional ADAS calibration function increases more revenue.
- Advanced coding and programming functions.
- An extended solution to support TPMS service.

المميزات

Technical details

- | | | |
|--------------------|-------------------------|----------------|
| ● Operation System | Android 10.0 | ● نظام التشغيل |
| ● Display | 800*1920 , "10.1 | ● عرض |
| ● CPU | 2.0GHz, Quad-core | ● المعالج |
| ● Memory | 4GB | ● ذاكرة |
| ● Storage | 64GB | ● ذن |
| ● Battery | 47.88Wh (7.6V, 6300mAh) | ● بطارية |
| ● Camera | Rear 8MP | ● كاميرا |
| ● VCI Connection | Bluetooth | ● VCI اتصال |
| ● Dimension | 40.5*190.5*274 mm | ● البعد |

1402111

LAUNCH® X-431 Series

جهاز تشخيص و كشف اعطال Multi-System Diagnostic & Service Tool X-431PRO3SE



Features

4GB+64GB

المميزات

- Upgraded Android 10.0 operation system, 4GB memory and 64GB storage ensure faster and smooth diagnosis.
- Brand new designed VCI supports even more communication protocols, e.g. CAN, CAN FD, DoIP*, etc. (*Need an extra DoIP cable)
- Wireless communication offers flexible and easy connections for diagnostics, while a cabled connection offers a fast and stable connection for advanced work like coding.
- Full system OE-Level diagnostics on 1996 and newer U.S., European and Asian vehicles
- Full diagnostic functionality includes comprehensive OBD II diagnostics, read/clear DTCs, bi-directional control, remote diagnosis, live data streaming, coding, etc.
- Optional ADAS calibration capability for calibrating LDW, RCW, AVM, NV, BSD and ACC system with the X-431 ADAS calibration tools.
- Expand diagnostic coverage via "Mail".
- One-stop Info Center includes vehicle repair information and latest updates.
- Review the previous diagnostic report via the Diagnostic History.

Technical details

الموصافات الفنية

- | | | |
|--------------------|-------------------------|----------------|
| ● Operation System | Android 10.0 | ● نظام التشغيل |
| ● Display | 800*1280 ,*8 | ● عرض |
| ● CPU | 2.0GHz, Quad-core | ● المعالج |
| ● Memory | 4GB | ● ذاكرة |
| ● Storage | 64GB | ● تخزين |
| ● Battery | 47.88Wh (7.6V, 6300mAh) | ● بطارية |
| ● Camera | Rear 8MP | ● كاميرا |
| ● VCI Connection | Bluetooth | ● VCI اتصال |
| ● Dimension | 39.5*166*234 mm | ● البعد |

1402112

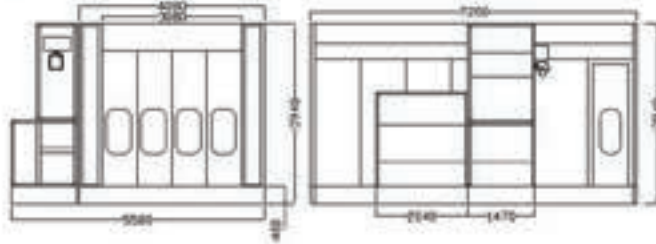
**Line Draw****ابعاد الجهاز****Product Usage****استخدام المنتج****Features****المميزات**

- Upper lighting: 8 units, each unit contains 4 bulbs with a capacity of 36 watts (optional).
- Side lighting: 8 units, each unit contains 2 bulbs with a capacity of 36 watts (optional).
- Intake turbine: 1 turbine with a capacity of 7.5 kW per fan
Total capacity 24,000 cubic meters/hour.
- Exhaust turbine: 1 turbine with a capacity of 7.5 kW per fan
Total capacity 24,000 cubic meters/hour.
- Italian Riello BS lighter operating: Diesel brand 20/4.
- Heat exchanger: Stainless steel heat exchanger equipped with an explosion-proof safety system.
- Filter system: primary filter, ceiling filter, floor filter, and carbon filter inside the cabin.
- He found 4 filters for the ceiling, front, back, exit, door, and wall

Technical details**الموصفات الفنية**

- | | |
|--|-------------------|
| ● Air Intake Kit | مجموعة سحب الهواء |
| ● Exhaust Fan 24000 m ³ /h - 7.5 HP | مروحة العادم |
| ● Fresh Air Fan 24000 m ³ /h - 7.5 HP | مروحة هواء نقي |
| ● Thermal Group 183.0000 cal/hr | المجموعة الحرارية |
| ● Light 36*40 W | إضاءة |
| ● Electricity source 380 V | مصدر الكهرباء |
| ● Wall Thickness 50 mm | سمك الحائط |
| ● Ground Network 2 lines | شبكة أرضية |
| ● Dimension 4 m*7 m | ابعاد |

100553



GEC Tools



Features

- Trolley/Trolley 7 Drawer with 196 Pieces Heavy duty kit,
- Trolley equipped with locks and one drawer holds up to 25 kg
- grey color and the kit is placed in a soft sponge
- The 196 pieces consist of the following
- a set of 62 pieces including hexagonal keys
- a variety of 72 bits size 2/1 ,8/3 ,4/1 inch
- a multi-ribbed wrench and wrench set, 25 pieces
- A set of 26 screwdrivers and hammer pliers in addition to 11 other assorted pieces.

المميزات

تروليي عدة كامل طقم 231 قطعة 7 درج Trolley Tools Kit Set 231 Pieces 7 Drawers TROLLEY 231 PC



17071



GEC Tools

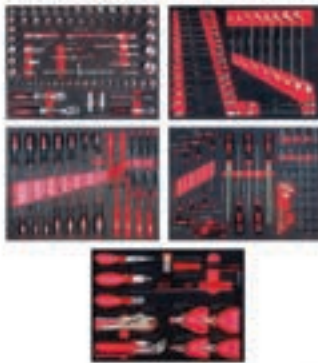

Features

- Trolley/Trolley 7 Drawer with 196 Pieces Heavy duty kit,
- Trolley equipped with locks and one drawer holds up to 25 kg
- grey color and the kit is placed in a soft sponge
- The 196 pieces consist of the following
- a set of 62 pieces including hexagonal keys
- a variety of 72 bits size 2/1 ,8/3 ,4/1 inch
- a multi-ribbed wrench and wrench set, 25 pieces
- A set of 26 screwdrivers and hammer pliers in addition to 11 other assorted pieces.

المميزات

تروليي عدة كامل طقم 196 قطعة 7 درج Trolley Tools Kit Set 196 Pieces 7 Drawers TROLLEY 196 PC



17073



GEC Tools

جهاز كبس واختبار دورة تبريد السيارات (الردياتير) Master Cooling System Detector And Radiator Car Pressure Tester Temperature Tool Kit GEC-G1022

Features

المميزات

- This professional tool is designed for finding internal and external leaks in a vehicle's cooling system.
- It allows easy change of coolant and testing of radiator, heater core, and radiator cap.
- It features a wide selection of caps and a pressure testing pump.
- Gauge test pressure from 2.5 - 0 BAR / 35 - 0 PSI
- Comes with a full set of instructions for easy application.



GEC Tools

زرجينة سوستة مساعد 370 مم Oil Combustion Spraying Pressure Meter Kit GEC-G1012

Features

المميزات

- Can be used on all petrol engines, gives readings in PSI and BAR, measures pressures of up to 20 BAR (300PSI). Kit includes 3 rubber hoses with brass adaptors suitable for spark plug thread sizes stated above, plus valve and o-ring replacement set.
- Suitable for 14/12/10mm spark plug threads
- Can be used on all petrol engines
- Gives readings in PSI and BAR
- Measures pressures of up to 20 BAR (300PSI)
- Kit includes 3 rubber hoses with brass adaptors above
- Supplied with valve and o-ring replacement set



GEC Tools

جهاز اختبار ضغط طللمبة وفاكيوم محرك Vacuum & Fuel Pump Compression GEC-G1015

Features

المميزات

- It measures the vacuum of the engine to diagnose faults up to 70 hg
- The pressure of the gasoline pump can be used up to 10 bar



140528

GEC Tools

Features

- A comprehensive kit for testing the compression on both petrol and diesel vehicles features 600 psi gauge with large rubber bumper, straight and right angled quick connect fittings and an extensive range of spark/glow plug and injector adaptors
- This kit will cover most of modern car, van, truck, bus size: 10, 12, 14, 16 mm
- Injector adaptor m20, m22, m24 and ford stanadyne injectors plus clamp on injectors.

المميزات



140511

جهاز اختبار كبس محرك الديزل GEC Cylinder Pressure Meter For Diesel Truck GEC-G1033

GEC Tools

Features

- 4pcs adapters for a wide number of vehicles M10, M12, M14, M18
- 2pcs straight and angled adapter tubes
- 3 inch gauge with dial color scale, rubberized protector with reading from 0 to 300 PSI
- 14" extension 300PSI hose

المميزات



140510

جهاز كبس موتور Engine Cylinder Compression Tester Kit GEC-G1005

GEC Tools

Features

- Designed to detect a variety of common engine faults related to the loss of compression
- Able to detect worn piston rings, worn valves, cracks in cylinder walls and blown head gaskets
- Suitable for use on most gasoline engines with 10 or 12mm spark plugs
- Tester checks the amount of leakage in an engine cylinder and helps determine the source
- Double gauge system, ideal for testing trucks and cars where clearance is minimal

المميزات

مقاس اختبار سلندر بنزين 20 بار 4 قطع Cylinder Leak-down Compression Tester Kit GEC-G1016



14058

A man with a beard, wearing a white t-shirt and orange overalls, is operating a manual oil press machine. He is looking upwards and to the right, with his right hand raised towards the ceiling. The machine is a complex piece of metal machinery with a large funnel-shaped hopper on top and a red cylindrical base. The background shows a workshop with shelves and a window.

حلول مراکز الزيتوت و الشحوم



Grease Pumps Series



Features COMPRESSION RATE 1:100 المميزات

- Suitable for working on short and medium lubrication lines on vehicle and equipment lubrication lines.

Technical details

● Model	4081TWDE	4081
● Air Intake	2:8 Bar	2:8 Bar
● Compression Ratio	1:100	1:100
● Drainage	5000 gm/min	2700 gm/min
● Grease Rxit	1/2 Inch	1/4 Inch
● Working On A Barrel	180 kg	180 kg

30117

30115

طلمبات تشحيم بالهواء Pneumatic Grease Pumps



Features COMPRESSION RATE 1:50 المميزات

- Suitable for working on long lubrication lines on heavy equipment lubrication

المواصفات الفنية

● Model	4080	4060	4020
● Air Intake	2:8 Bar	2:8 Bar	2:8 Bar
● Compression Ratio	1:50	1:50	1:50
● Drainage	2900 gm/min	2900 gm/min	2900 gm/min
● Grease Rxit	1/4 Inch	1/4 Inch	1/4 Inch
● Working On A Barrel	180 kg	60-50 KG	18-25 kg

30114

30113

30111



Grease Pumps Series

نظام تشحيم متكامل Pneumatic Grease Supply Kits



طلمبة تشحيم ٤٠٠ بار

صنظم ضغط هواء

دلوام تشحيم معدة على

كباس وصاعط شحيم

وحلة معدنية ٣٦ درجة دوران

مسدس تشحيم

Features المميزات

- Convenient weight for hand holding and handling.
- Two rear wheels for easy movement.
- Suitable barrel capacity.

30119



Grease Pumps Series

نظام تشحيم متكامل متحرك Mobile Pneumatic Grease Supply Kits



4960 C

ظلمية تشحيم 4.0 بار

منظم ضغط هواء

تسهل الحركة

كباس وصاعط شحم

مسدس تشحيم

Features

المميزات

- Suitable for on- and off-site work
- Easy to move and handle
- Large lubrication barrel capacity

Optional

303314

اختياري



4980 C



4910



4911



4990 C



Grease Pumps Series

نظام تشحيم متكامل Pneumatic Grease Supply Kits



بكرة هواء دائرية الرجراج

ظلمية تشحيم من 8.0-12.0 بار

منظم دخول هواء

خراطيم طول مختلف على حسب الاحتياج

كباس وصاعط شحم

مسدس تشحيم

190210



Oil Pumps Series



مشاحم يدوي Manual Grease Supply Kits



Technical details

Model	2014	2025	2073	2040	المواصفات الفنية
Compressed Air Supply	2:8 Bar	2:8 Bar	2:8 Bar	2:8 Bar	● موديل
Compression Ratio	1:5 Bar	1:5 Bar	1:3 Bar	1:1 Bar	● دخول الهواء
Delivery	15 L/min	40 L/min	16 L/min	48 L/min	● نسبة الإنضغاط
Outlet Pressure	40 Bar	40 Bar	24 Bar	10 Bar	● التصريف
Grease Exit	3/4 Inch	1/2 Inch	1/2 Inch	3/4 Inch	● الضغط الخارج
Working On A Barrel	208 L	208 L	208 L	208 L	● خروج الزيت
	20212	20213	20216	20214	● تعمل على برميل



Oil Pumps Series

طلمبات نقل سوائل Electric Oil Pumps



Technical details

Model	6122	6135	المواصفات الفنية
Voltage	220 V	220 V	● موديل
Power	0.55 KW	2.2 KW	● الجهد الكهربى
Outlet Pressure	10 Bar	8-30 BAR	● القدرة
Delivery	10.5 l/min	34 l/min	● ضغط المخرج
Connections IN-OUT	1/2 Inch	1 Inch	● التصريف
	40116	40117	● قطر الخرج

مشاحم يدوي

Manual Grease Supply Kits



MADE IN ITALY

Grease Pumps Series

750 bar



5110



5100



Technical details

● Model	5110
● Barrel Capacity	5 kg
● Grease Pressure	750 Bar
● Grease Disbatch	8 gm / 1 Prssure

30118

المواصفات الفنية

● موديل	5100
● سعة البرميل	16 kg
● ضغط الشحم	250 Bar
● خروج الشحم	8 gm / 1 Prssure

30116



MADE IN ITALY

Greasing Tools

مسدس تشحيم ديجيتال
Digital Grease Flow
Meters

4286

Features

● Max Pressure	400 Bar	● أقصى ضغط
● Flow	2 Kg/ Min	● التصريف

30212

المميزات



MADE IN ITALY

Greasing Tools

مسدس تشحيم
Accessories For Grease
Lubrication

4205

Features

● High pressure grease gun equipped with flexible outlet 30 cm
--

30213

المميزات



MADE IN ITALY

Greasing Tools

ديفرام / ماسح شحم لبرميل
Digital Grease Flow
Meters

200KG

303311

60KG

30339

20KG

303310



MADE IN ITALY

Greasing Tools

غطاء برميل
Barrel Cover

200KG

30335

60KG

30333

20KG

30334



نظام سحب زيت هائطي بالهوا pneumatic piston pump

3099

Grease Pumps Series



عدد (5) نواخيره

طلمية سحب زيت

جاملي للوصلات الشفافة

عداد ضغط للتفرع في التران

جانب لتفوق المنوية في التران



Technical details

● Required Pressure	4-1 Bar
● Compression Ratio	1:1
● Delivery	140 L/min
● Output Pressure	4 Bar
● Weight	11 Kg

20313

المواصفات الفنية

● الضغط المطلوب	4-1 Bar
● نسبة الإنضغاط	1:1
● التصريف	140 L/min
● الضغط الخارج	4 Bar
● الوزن	11 Kg



Grease Pumps Series

مزيتة يدوي Portable oil dispensing unit

5200



Features

- Manual oil dispensing units consist of a portable container with wheels.
- Suitable for dispensing small amounts of oil in applications where no other power source is available.

Technical details

● Tank Capacity	16 L
● Hose Length	1.5 m
● Weight	7.3 Kg
● Dimensions	660*320*250 mm
● Delivery	8 L/min

20219

المميزات

المواصفات الفنية

● سعة الخزان	16 L
● طول الخرطوم	1.5 m
● الوزن	7.3 Kg
● الابعاد	660*320*250 mm
● التصريف	8 L/min



Oil Suction Unit

مشاحم يدوي

Combined Waste Oil Drainers And Suction Units



Features

- Combined units that can be used as waste oil gravity drainers, but also as waste oil suction units thanks to a pneumatic Venturi valve by which a vacuum of up to 0.8 bar inside of the container can be created when compressed air at a pressure of 10 – 7 bar is connected on it.
- The waste oil can be sucked with appropriate suction probes or suction adapters inserted in the dip-stick tube of the motor.
- For an ideal result the oil temperature should not be less than 80 – 60°C during the suction process. The unit can be used also autonomously since it does not require a continuous air supply.

المميزات

Technical details

● Model	3065	3090	3167	3198
● Total Capacity	68 L	90 L	68 L	90 L
● Upper Part	8 L	10 L	8 L	10 L
● Bottom Tank	60 L	80 L	60 L	80 L
● Discharge Time	1.5 Min	1.5 Min	1.5 Min	1.5 Min
● Weight	29 Kg	32 Kg	30 Kg	34 Kg

203111

20311

203110

20315

المواصفات الفنية

- موديل
- السعة الاجمالية
- جزء العلوي
- خزان سفلي
- وقت التفريغ
- الوزن



ماكينة سحب زيت من دورة الفرامل Brake Bleeders Units

Oil Suction Unit



3416



Electric
20319

3406



Pneumatic
20314

Features

- Brake bleeding unit with two chambers which are hermetically separated by an elastic diaphragm. One chamber of the container contains the brake fluid, the other chamber serves as reservoir for the compressed air.
- The diaphragm permits to separate the brake fluid and the compressed air, avoiding like that the risk of an emulsion.

المميزات



ماكينة سحب زيت من دورة الفرامل Mobile Waste Oil Suction Systems

Oil Suction Unit



3406

Technical details

المواصفات الفنية

- Maximum Pressure 4 Bar أقصى ضغط
- Tank Capacity 20 L سعة الخزان
- Air Consumption Rate 180 L/min معدل استهلاك الهواء
- Absorption Rate 0.6 to 1.6 L/min معدل الامتصاص

Features

- Mobile waste oil suction unit, composed of a pneumatic rotary gear pump, suction hose, kit of suction probes in different diameters, suction adapters, storage bowl, two wheels trolley and 20 l – capacity plastic can for collection of the sucked oil.
- Can be used also to suck out diesel from vehicle fuel tanks.

المميزات

20313



ماكينة سحب زيت من دورة الفرامل Brake Bleeders Units

Control Guns



Features	المميزات	Features	المميزات	Features	المميزات	Features	المميزات
● Mechanical flow meter with oil meter with control gun.	● Electronic flow meter with the meter with the possibility of determining the quantity	● Electronic flow meter with oil control gun.	● Mechanical flow meter with indicator for oil with control gun.	● Metal outlet diameter 12 mm.	● With control gun, metal outlet diameter 12mm	● Metal outlet diameter 12 mm	● Metal outlet diameter 12 mm
● Automatic anti-drip nozzle and 2/1" diameter inlet.	● Automatic anti-drip nozzle and 2/1" diameter inlet	● Automatic anti-drip nozzle and 2/1" diameter inlet	● Automatic anti-drip nozzle and 2/1" diameter inlet				

Technical details

Model	2608	2836	2633	2712	المواصفات الفنية
● Discharge Rate	15 L/min	1-35 L/min	1-35 L/min	15 L/min	● الموديل
● Works On Materials With A Temp.Of	10°C:50°C	10°C:50°C	10°C:50°C	10°C:50°C	● معدل التصريف
● Maximum Operating Pressure	70 Bar	80 Bar	80 Bar	50 Bar	● يعمل علي مواد بدرجة حرارة من
● Accuracy	(+/-) 0.5%	(+/-) 0.5%	(+/-) 0.5%	(+/-) 0.5%	● أقصى ضغط للتشغيل
● Maximum Meter Reading	9999 L	9999 L	9999 L	99999 L	● الدقة
● Weight	1.6 Kg	1.6 Kg	1.4 Kg	1.1 Kg	● القراءة القصوي للعداد
					● الوزن

20411

204110

20417

20414



Control Gun

مسدس زيت عادية Manual oil gun 2181



Features

- Oil control gun, outlet made of flexible rubber
- Automatic anti-drip nozzle and 1/2" diameter inlet

30212

المميزات



محول توصيل اسفل الخزان 1000 لتر قطر 70 مم ووصلة 1 بوصة

Under tank connection adapter 1000 liters diameter 70 mm 1 inch connection



30213

بكر خرطوم ذاتي الارجاع

Automatic Hose Reels Standard Series



Reel Hoses Series



9013

Features المميزات

- Self Reflux Hose Ball Metal Iron Red Color
- In the case of a hose 1/2 inch
- suitable up to 15 meters long
- It has a place to mount in the wall for heavy duty



9016

Features المميزات

- Self Reflux Hose Ball Metal Iron Red Color
- In the case of a hose 1/2 inch
- suitable up to 15 meters long
- It has a place to mount in the wall for heavy duty



9084

Features المميزات

- Self Reflux Hose Ball Metal Iron Red Color
- In the case of a hose 1 inch
- suitable up to 8 meters long
- It has a place to mount in the wall for heavy duty



9095

Features المميزات

- Self Reflux Hose Ball Metal Iron Red Color
- In the case of a hose 1 inch
- suitable up to 8 meters long
- It has a place to mount in the wall for heavy duty

Technical details

Model	9013	9016	9084	9095
Maximum Operating Pressure	600 Bar	600 Bar	100 Bar	600 Bar
Hose Entrance Dim.	1/2 Inch	1/2 Inch	1 Inch	1 Inch
Hose Exit Dim.	1/2 Inch	1/2 Inch	1 Inch	1 Inch
Weight	26 kg	14 kg	27 kg	14 kg

المواصفات الفنية

- الموديل
- أقصى ضغط للتشغيل
- المدخل
- الوزن

20111

20112

20115

20116



9083

Features المميزات

- Self Reflux Hose Ball Metal Iron Red Color
- In the case of a hose 1/2 inch
- suitable up to 35 meters long
- It has a place to mount in the wall for heavy duty



9408

Features المميزات

- Self Reflux Hose Ball Metal Iron Red Color
- In the case of a hose 2/1 inch
- suitable up to 15 meters long
- It has a place to mount in the wall for heavy duty



9021

Features المميزات

- Self Reflux Hose Ball Metal Iron Red Color
- In the case of a hose 1/2 inch
- suitable up to 20 meters long
- It has a place to mount in the wall for heavy duty

Technical details

Model	9083	9021	9408
Maximum Operating Pressure	600 Bar	600 Bar	20 Bar
Hose Entrance Dim.	1/2 Inch	1/2 Inch	3/8 Inch
Hose Exit Dim.	1/2 Inch	1/2 Inch	3/8 Inch
Weight	26 kg	18 kg	8.3 kg

المواصفات الفنية

- الموديل
- أقصى ضغط للتشغيل
- المدخل
- الوزن

20113

20117

20118



مصفاة زيت للبيارة تناسب زيت المواتير و زيت التروس Pit Gravity Waste Oil Drainer

Waste Oil Drainers Series

3186



Features

- Pit gravity waste oil drainer, suitable for the draining of motor oil, gear oil or differential oil from trucks and passenger cars.
- Available with collection capacity of 70 l and 110 l, with anti splash grid and metal rollers.
- The unit can be discharged by gravity through the laterally mounted 4/3" drain valve or by using an evacuation pump with suction hose and female quick coupling to be connected to the male coupling installed on the drainer.

المميزات

Technical details

- Model 3186
- Collection Capacity 70 L
- Width Adjustment Range Min 900 mm - Max 1300 mm
- Connections 3/4" BSP (F)
- Weight 27 kg

المواصفات الفنية

- الموديل
- قدرة التحصيل
- نطاق تعديل إديث (M)
- اتصال
- وزن

20112



قاعدة عدد 2 برميل سعة 208 كيلو جرام Tank Service Base 400

Spill Containment Pallets Series

8532



Features

- Spill containment pallet in painted steel, with pallet feet, suitable for the storage of 2 drums of 208 l.
- Sump capacity: 286 l. Prepared for the installation of a mounting rack consisting of steel posts and steel panels
- suitable for the installation of equipment.

المميزات

20117



عداد سولار ديجيتال Digital Solar Meter

Solar Meter Series



OCIO

Features

- The device for measuring the level of the product inside the tank by means of insert a sensitive hose 10 meters long from the upper hole For the tank until you reach the lowest point in the tank, requires insertion
- Accuracy: (+/-) 1%

المميزات

- Self Reflux Hose Ball Metal Iron Red Color
- In the case of a hose 1/2 inch suitable up to 15 meters long
- It has a place to mount in the wall for heavy duty



2602

Features

- Box to show battery charge
- The screen can be moved from the metal chassis up to 15 meters
- There are four different units of measurement to choose from

المميزات

- Box to show battery charge
- The screen can be moved from the metal chassis up to 15 meters
- There are four different units of measurement to choose from



2604

Features

- He found four different units of measurement to choose between the counter contains a set of alarms to protect against the following situation:
- 1. In case of exceeding the permissible discharge

المميزات

- He found four different units of measurement to choose between the counter contains a set of alarms to protect against the following situation:
- 1. In case of exceeding the permissible discharge



2603

Features

- He found four different units of measurement to choose between the counter contains a set of alarms to protect against the following situation:
- 1. In case of exceeding the permissible discharge

المميزات

- He found four different units of measurement to choose between the counter contains a set of alarms to protect against the following situation:
- 1. In case of exceeding the permissible discharge

Technical details

Model	2602	8722+2604	2603	الموديل
Discharge	40-220 L/min	20-250 L/min	50-500 L/min	التصريف
Maximum Operating Pressure	10 Bar	20 Bar	20 Bar	أقصى ضغط للتشغيل
Number Of Digits To Read	5 Digits	5 Digits	5 Digits	عدد الخانات للقراءة
Hose Entrance Dim.	1.5 Inch	2 Inch	3 Inch	المدخل

402210

40218

40215

المواصفات الفنية



2868



2601

PIUSI



2865



2823

Technical details

Model	2868	2601	2865	2823	الموديل
Discharge	20-120 L/min	5-120 L/min	20-120 L/min	50-210 L/min	التصريف
Maximum Operating Pressure	3.5 Bar	20 Bar	10 Bar	20 Bar	أقصى ضغط للتشغيل
Number Of Digits To Read	4 Digits	Digital	4 Digits	Digital	عدد الخانات للقراءة
Hose Entrance Dim.	1 Inch	1 Inch	1 Inch	1 Inch	المدخل
Accuracy	(+/-) 1%	(+/-) 1%	(+/-) 0.5%	(+/-) 1%	الدقة

40214

40216

40212

40213

المواصفات الفنية

طلبة تموين سولار Solar Supply Pump



Solar Supply Series

6249



6741



Technical details

Model	6249	6741	المودل
Discharge	43 L/min	55 L/min	التصريف
Power	240 W	370 W	القدرة
Solar Hose Fiameter	3/4 Inch	3/4 Inch	قطر خرطوم السولار
long At Ends	2 m	4 m	الطول بالنهايات
Suction Hose From The Tank Fiameter	25 mm	25 mm	قطر خرطوم الشفط من الخزان
Inlet and Outlet	1 Inch	1 Inch	مدخل ومخرج
Italian Heavy Duty Supply Pistol	1 Inch	1 Inch	مسدس تموين هيفي ديوتي ايطالي
Power Source	24 V Battery	220 V	مصدر الكهرباء

40112

40113

المواصفات الفنية



Solar Supply Series

6739



6738



طلبة تموين سولار بالكهرباء Solar Supply Pump Electrolyte

Technical details

Model	6739	6738	المودل
Discharge	100 L/min	55 L/min	التصريف
Power	750 W	370 W	القدرة
Solar Hose Fiameter	1 Inch	1 Inch	قطر خرطوم السولار
long At Ends	2 m	2 m	الطول بالنهايات
Suction Hose From The Tank Fiameter	25 mm	25 mm	قطر خرطوم الشفط من الخزان
Inlet and Outlet	1 Inch	1 Inch	مدخل ومخرج
Italian Heavy Duty Supply Pistol	1 Inch	1 Inch	مسدس تموين هيفي ديوتي ايطالي
Power Source	220 V	220 V	مصدر الكهرباء

40114

40112

المواصفات الفنية



Pump Series

طلمبة نقل سوائل Fluid Transfer Pump



Features

- Rotary electric pump for diesel transport
- ON/OFF equipped with power switch
- BYPASS is inside the pump

المميزات

Technical details

● Model	6257	6256
● Electricity	24 V	12 V
● Power	400 W	400 W
● Discharge	80 L/min	40 L/min
● Links	1 Inch	1 Inch

401114

401111

المواصفات الفنية

- الموديل
- الكهرباء
- القدرة
- التصريف
- الوصلات



Features

- The body is made of anti-corrosion cast iron and thermally insulated
- Equipped with a non-return winding
- BYPASS is inside the pump

المميزات

Technical details

● Model	6935	1056
● Electricity	12 V	220 V
● Power	250 W	400 W
● Pump pressure		6 Bar
● Discharge	50 L/min	60 L/min
● Entrance and exit	1 Inch	3/8 Inch

401110

40119

1056



المواصفات الفنية

- الموديل
- الكهرباء
- القدرة
- ضغط الطلمبة
- التصريف
- مدخل ومخرج

PIUSI MADE IN ITALY

Cube Series

CUBE70



CUBE90



طلمبة تموين سولار Solar Supply Pump

Technical details

- Model
- Discharge
- Power
- Solar Hose Fiameter
- long At Ends
- Accuracy
- Italian Heavy Duty Supply Pistol
- Power Source

	CUBE70	CUBE90
Model	CUBE70	CUBE90
Discharge	70 L/min	55 L/min
Power	500 W	700 W
Solar Hose Fiameter	1 Inch	1 Inch
long At Ends	2 m	4 m
Accuracy	(+/-) 1%	(+/-) 1%
Italian Heavy Duty Supply Pistol	1 Inch	1 Inch
Power Source	220 V	220V

401211

401218

المواصفات الفنية

- المودل
- التصريف
- القدرة
- قطر خرطوم السولار
- الطول بالنهايات
- الدقة
- مسدس تموين هيفي ديوتي ايطالي
- مصدر الكهرباء

FLEXBIMEC MADE IN ITALY

Pump Series



طلمبة نقل زيت بالهواء Air Oil Transfer Pump 1058

Features

- For transporting low-viscosity liquids
- Made of stainless steel

Technical details

		المواصفات الفنية
● Max Pressure	4 Bar	● الضغط
● Discharge	10.5 L/min	● التصريف
● Power	1500 W	● القدرة
● Entrance and exit	3/8 Inch	● مدخل ومخرج
● Electricity Source	220V	● مصدر الكهرباء

20211

المميزات

PIUSI MADE IN ITALY

Pump Series



طلمبة تموين سولار Solar Supply Pump E3000

Technical details

		المواصفات الفنية
● Max Pressure	1.8 Bar	● الضغط
● Discharge	550 L/min	● التصريف
● Power	1500 W	● القدرة
● Entrance and exit	2 Inch	● مدخل ومخرج
● Electricity Source	220V	● مصدر الكهرباء

401115

PIUSI MADE IN ITALY
Filter Series

فلتر تنقية بالقاعدة
Base Purification Filter



CF60



CF100

Technical details

المواصفات الفنية

	CF60	CF100	
● Model	CF60	CF100	● المودل
● Pressure	12 Bar	12 Bar	● الضغط
● Discharge	60 L/min	100 L/min	● التصريف
● Filter Capacity	10 Micrometer	5 Micrometer	● سعة الفلترية
● Entrance and exit	1 Inch	1 Inch	● المدخل و المخرج
● Dimensions	140*120*200 mm	140*285*390 mm	● الأبعاد
● Weight	1 kg	2.6 kg	● الوزن

404128

404129

PIUSI MADE IN ITALY
Filter Series

فلتر تنقية بالقاعدة
Base Purification Filter



6600

6607

Technical details

المواصفات الفنية

	6600	6607	
● Model	6600	6607	● المودل
● Pressure	5 Bar	5 Bar	● الضغط
● Discharge	70 L/min	100 L/min	● التصريف
● Filter Capacity	30 Micrometer	5 Micrometer	● سعة الفلترية
● Entrance and exit	1 Inch	1 Inch	● المدخل و المخرج
● Dimensions	140*285*390 mm	140*285*390 mm	● الأبعاد
● Weight	2 kg	2.3 kg	● الوزن

404411

404129

A close-up photograph of a person's hands wearing red, textured work gloves. The person is holding a blue and silver refrigerant gauge connected to a car's engine. The background is a blurred workshop setting with various mechanical parts and tools.

حلول مراکز شحن فریون التکیف



A/C Machine Series

ماكينة سحب زيت الفتيس الأوتوماتيك Automatic Transmission Cleaner And Oil Exchanger ATF 3000 PRO

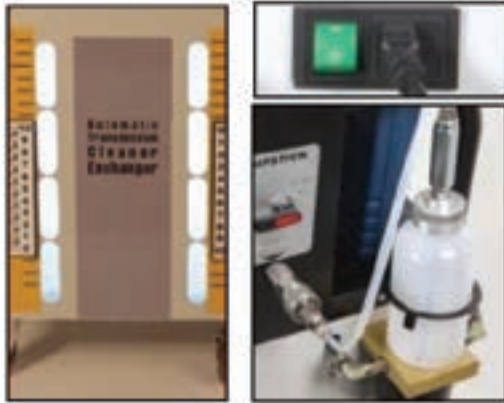

Features

- ATF is an automatic transmission oil change device. It is based on changing the transmission oil of most types and models of transmission, automatic transmission, which helps restore the speed performance of the gearbox and reduces vibrations and oil consumption.
- It is equipped with a complete set of connections to suit European, Japanese and Korean cars. And the Asian one.
- It determines the quantity precisely to avoid problems with the amount of excess/deficient oil.
- It withdraws the old oil and pumps it out again accurately, it performs a full cycle washing process to remove all sediments, to access the Smart Pack database, the possibility of entering the system, via the Internet.

المميزات

Technical details

- Kit 1: It contains the fittings of EU and Asian cars dated <2001.
- Kit 2: it contains adapters and fittings for cars from 2002 to the most recent ones.
- Dipstick: Device for operating on sealed gearboxes without heat exchanger or in case.
- SmartPack: Password for free access (for 12 months) to the database with reserved technical information (pictures, a fitting location, etc) and video with a practical demonstration performed on the car.
- Magnetic liters' counters: Useful for visual control of the levels (used oil, new oil).
- 220V version with power switch and protection against short circuits and overloads.
- Lighting of the internal tanks: Essential for the visual control of the different types of ATF oils in the tank
- 500ml additive injector with protection against mishandling.

المواصفات الفنية

- المجموعة ١: تحتوي على تجهيزات سيارات الاتحاد الأوروبي وآسيا بتاريخ <2001
- المجموعة ٢: تحتوي على محولات وتجهيزات للسيارات من عام ٢٠٠٢ إلى أحدثها
- مقياس العمق: جهاز للعمل على علب التروس المختومة بدون مبادل حراري أو في حالة الباقية الذكية: كلمة مرور للوصول المجاني (لمدة ١٢ شهرا) إلى قاعدة البيانات مع المعلومات الفنية المدجوزة (الصور، موقع التركيب، إلخ) والفيديو مع عرض عملي يتم إجراؤه على السيارة
- عدادات اللترات المغناطيسية: مفيدة للتحكم البصري في المستويات (زيت مستعمل، زيت جديد)
- إصدار ٢٢٠ فولت مع مفتاح الطاقة والحماية ضد الدوائر القصيرة والأحمال الزائدة
- إضاءة الخزانات الداخلية: ضرورية للتحكم البصري في الخزان ATF الأنواع المختلفة من زيوت
- حافن مضاف ٥٠٠ مل مع حماية ضد سوء التعامل

201113



Technical details

● Temperature	5-50°C	● درجة الحرارة
● Maximum Pressure	18 Bar	● أقصى ضغط
● Electricity	220 V / 50 Hz	● كهرباء
● Scale	80 mm	● مقياس
● Tank Size	40 mm	● مقياس الخزان
● Hose	3 meters /SAE-J2196	● خرطوم
● Compressor	1/2 HP, 14 cc	● الكمبريسور
● Vacuum Pump	60 l/min, 1.8 cfm	● مضخة التفريغ
● Final Pump	75 microns, 10 pa	● المضخة النهائية
● Propeller & Condenser	Yes	● المروحة والمكثف
● Filter Dryer	80 kg	● مجفف الفلتر
● Tank	22 L	● الخزان
● Oil Bottle	250 ml	● زجاجة الزيت
● Gas Load Cell	1g/30 kg	● خلية تحميل الغاز
● Oil Loading Cell	1g/30 kg	● خلية تحميل الزيت
● Printer	Optional	● الطابعة
● SD Database	Yes	● قاعدة بيانات SD

80185

A close-up photograph of a person's hands, wearing red safety gloves, using a black battery charger. The charger is connected to a car battery. The person is holding the black handle of the charger, which has a red clamp attached. The battery is black and has various labels and terminals. The background is a blurred view of the car's engine compartment.

حلول مراكز الكهرباء



MADE IN ITALY

Test&Charge Series

Features

- Suitable for charging lead batteries; WET serviceable and maintenance free, AGM, AGM Power, GEL, Start&Stop.
- **Multi step charging**
The batteries are charged by applying sophisticated multi-step programs. Desulphation and analysis of the battery are included.
- **High efficiency**
"I-U" Charging characteristic (constant current - constant voltage) minimises battery charging time.
- **"Floating" (max power) & "Pulse Maintenance" maintenance function.**
They can remain connected to the battery for a long time. They keep the battery ready for use through the pulse charge.
- **"Recond Battery" refresh function**
It regenerates batteries that have undergone heavy discharge cycles.
- **Safety guaranteed**
Designed to protect vehicle electronics. Non-sparking. Reverse polarity protected and short-circuit proof.
- **IP65**
Lightweight and compact battery charger. Built for outdoor use.

المميزات

Technical details

- | | | |
|-----------|-------------------------|---------------|
| ● IN-put | 220 V | ● مصدر الطاقة |
| ● Voltage | 12 V | ● الفولت |
| ● Current | Min 14Ah-Max (225)150Ah | ● التيار |

1401123

Suitable For Vehicles



تاجر شحن وأختبار بطاريات ذكية Automatic battery chargers SM C70T



MADE IN ITALY

Test&Charge Series

Features

- **Stabilized power supply**
Power supply to support diagnostics and setup of automotive electronic control units. Back-up function to power vehicle electronics while the battery is being replaced.
- **Power supply for showrooms vehicles**
(with or without battery): "lockup" function to avoid improper use; option for auto start up when powered by the network.
- Stabilized power supply adjustable in voltage and current for particular uses.
- Thanks to the SD Card reader, it is possible to update the software adding new charging programs.
- It is possible to use cables of different lengths.

المميزات

Technical details

- | | | |
|-----------|---------------------|---------------|
| ● IN-put | 220 V | ● مصدر الطاقة |
| ● Voltage | 12 V | ● الفولت |
| ● Current | Min 20Ah-Max 2400Ah | ● التيار |

1401124

Suitable For Vehicles



تاجر شحن وأختبار بطاريات ذكية Professional battery charger & stabilized power supply LIFE 120





Test&Charge Series

Features

- Suitable for charging lead batteries; WET serviceable and maintenance free, AGM, AGM Power, GEL, Start&Stop.
- **Multi step charging**
The batteries are charged by applying sophisticated multi-step programs. Desulphation and analysis of the battery are included.
- **High efficiency**
"I-U" Charging characteristic (constant current - constant voltage) minimises battery charging time.
- **"Floating" (max power)**
They can remain connected to the battery for a long time.
- **"Recond Battery" refresh function**
It regenerates batteries that have undergone heavy discharge cycles.
- **Safety guaranteed**
Designed to protect vehicle electronics. Non-sparking. Reverse polarity protected and short-circuit proof.
- **"Sulfated Battery Recovery"**
Desulphation / Equalization programme Regenerate batteries that have undergone heavy discharge cycles.

المميزات

Technical details

- | | | | |
|-----------|--------------------|--------------------|-------------|
| • Model | FL3713D | FL2213D | الموديل |
| • IN-put | 220 V | 220 V | مصدر الطاقة |
| • Voltage | 6-12-24 V | 6-12- 24V | الفولت |
| • Current | Min 15Ah-Max 450Ah | Min 30Ah-Max 260Ah | التيار |

1401125

1401122

المواصفات الفنية

تاجر شحن وأختبار بطاريات ذكية Automatic battery chargers



FL3713D



FL2213D



Test&Charge Series

Features

- **"Safe Charge & Boost"**
The system protects the electronic components on the vehicle against interference
- **4 Multi step charging programs**
The lead batteries WET, AGM, GEL, Ca/Ca and traction "Deep cycle", are charged by applying (Charging- Equalization- Maintenance ("Floating")- Desulphation)
- **"Booster" function** for start assist.
- **Temperature sensor**
It automatically compensates for any charging voltage according to ambient temperature.
- **Battery check**
The battery charger checks if the battery is sulphated and if it can store the charge.
- **"Memory"**
The function makes this product easy to use: Just connect the battery charger to a battery and to the mains and charging begins following the last programme set.
- **"Back-up"**
The function powers the vehicle electronics while the battery is being replaced so that saved data are not lost (radio and seat settings, for instance)

المميزات

Technical details

- | | | |
|----------------|-------------------|-------------|
| • In-put Power | 220 V | مصدر الطاقة |
| • Voltage | 6-12- 24V | الفولت |
| • Current | Min 5Ah-Max 800Ah | التيار |

1401128

المواصفات الفنية

تاجر شحن وأختبار بطاريات ذكية Professional microprocessor-controlled battery charger and starter.

SC3300B



Suitable For Vehicles





MADE IN ITALY

Test&Charge Series

Features

- **"Safe Charge & Boost"**
The system protects the electronic components on the vehicle against interference and overvoltage that may be created at the charging or quick starting procedures.
- **Multi step charging**
The batteries are charged by applying sophisticated multi-step programs.
- **Floating**
It can remain connected to the battery for a long time. Batteries are ready to use at all times.
- **Continuously adjustable charge current.** lets you charge optimally batteries of all capacities (Ah).
- **Charging with timer**
- **Boosting remote control**
- **Digital Voltmeter / Ammeter**
- **Overload protection with automatic reset**
- **Inversions of polarity and short circuits protection**
- **Heavy duty clamps**

المميزات

Technical details

- | Model | SC80/900 | SC60/700 | القدرة |
|---------|--------------------|-------------------|-------------|
| IN-put | 220 V | 220 V | مصدر الطاقة |
| Voltage | 12-24 V | 12-24 V | الفولت |
| Current | Min 5Ah-Max 1000Ah | Min 3Ah-Max 800Ah | الطيار |

1401127

1401126

تاجر شحن وأختبار بطاريات ذكية Professional microprocessor -controlled battery charger and starter.



SC80/900

SC60/700



MADE IN ITALY

Test&Charge Series

Features

- **Suitable for charging lead batteries**
WET serviceable and maintenance free, AGM, Start&Stop
- **Fast charging with timer**
- **Boosting remote control**
- **Overload protection**
- **Short circuits protection**
- **Inversions of polarity protection**
- **Manual charge breaker**
- **CU: %100 Copper windings**

المميزات

Technical details

- | Model | CLASS 5000 | CLASS 2500 | القدرة |
|---------|---------------------|-------------------|-------------|
| IN-put | 220 V | 220 V | مصدر الطاقة |
| Voltage | 12-24 V | 12-2 V | الفولت |
| Current | Min 35Ah-Max 1000Ah | Min 3Ah-Max 800Ah | الطيار |

1401127

1401126

تاجر شحن وأختبار بطاريات ذكية Professional microprocessor-controlled battery charger and starter.



CLASS2500

CLASS5000

Suitable For Vehicles





Test&Charge Series

Features

- **Suitable for charging lead batteries:**
WET serviceable and maintenance free, AGM, GEL and traction batteries DEEP CYCLE.
- **Multi step charging**
The batteries are charged by applying sophisticated multi-step programs.
- **High efficiency**
"I-U" Charging characteristic (constant current-constant voltage) minimises battery charging time.
- **Floating**
Can remain connected to the battery for a long time. Batteries are ready to use at all times.
- **Equalization program**
- **Temperature sensor**
Automatically compensates any charging voltage according to ambient temperature.
- **Safety guaranteed**
Non-sparking. Reverse polarity
- **protected and short-circuit proof.**
Battery charger suitable for van, boat, trolley, golf-cart, sweeper, lifter

Technical details

Model	FL3713D	الموديل
IN-put	220 V	مصدر الطاقة
Voltage	6-12-24 V	الفولت
Current	Min 30Ah-Max 270Ah	التيار

1401125

المميزات



تاجر شحن وأختبار بطاريات ذكية Automatic battery chargers DL3713D



Test&Charge Series

Features

- **Suitable for charging lead batteries**
WET serviceable and maintenance free, AGM, Start&Stop
- **Fast charging with timer**
- **Boosting remote control**
- **Overload protection**
- **Short circuits protection**
- **Inversions of polarity protection**
- **Manual charge breaker**
- **CU: %100 Copper windings**

Technical details

Model	CLASS20A	CLASS20A	الموديل
In-put Power	220 V	220 V	مصدر الطاقة
Voltage	12- 24V	12- 24V	الفولت
Current	Min 10Ah-Max 250Ah	Min 15Ah-Max 500Ah	التيار

1401121

1401123

المميزات



CLASS20A



CLASS50A

Suitable For Vehicles



Traction

SPIN

Test&Charge Series

جهاز اختبار البطارية والدينامو 12 فولت ديجيتال Battery and dynamo tester 12V Digital BT400

Technical details

- | | | |
|-------------------------------------|--------------------------------|---------------------------|
| Works on batteries | 12 and 24 volts in dynamo test | يعمل علي بطاريات |
| CCA Measurement Range | CCA 2000 - 40 | نطاق القياس |
| Software has 10 different languages | | سوفتوير به 10 لغات مختلفة |
| covered with an anti-shock case | | مغطى بجراب مضاد للصدمات |
| Dimensions | 140*100*30 mm | الابعاد |

140554



Works on types of batteries يعمل على انواع البطاريات

SPIN

Test&Charge Series

جهاز اختبار البطارية والدينامو 12 فولت ديجيتال وطابعة Battery and dynamo tester 12V Digital and printer BT900

Technical details

- | | | |
|-------------------------------------|--------------------------------|---------------------------|
| Works on batteries | 12 and 24 volts in dynamo test | يعمل علي بطاريات |
| CCA Measurement Range | CCA 2000 - 40 | نطاق القياس |
| Software has 10 different languages | | سوفتوير به 10 لغات مختلفة |
| covered with an anti-shock case | | مغطى بجراب مضاد للصدمات |
| Dimensions | 138*96*30 mm | الابعاد |

140553



Works on types of batteries يعمل على انواع البطاريات

SPIN

Test&Charge Series

جهاز اختبار البطارية والدينامو 12 فولت ديجيتال وطباعة وباركود Battery and dynamo tester 12V Digital, printer and Barcode BT1000

Technical details

- | | | |
|---|--------------------------------|--|
| Works on batteries | 12 and 24 volts in dynamo test | يعمل علي بطاريات |
| CCA Measurement Range | CCA 2000 - 40 | نطاق القياس |
| Software has 6 different languages | | سوفتوير به 6 لغات مختلفة |
| It has a barcode feature to track battery history | | به خاصية الباركود لتتبع تاريخ البطارية |
| covered with an anti-shock case | 235*103*68 mm | مغطى بجراب مضاد للصدمات |
| Dimensions | | الابعاد |

140552



Works on types of batteries يعمل على انواع البطاريات

A detailed photograph of an air compressor system. On the left, a black rectangular motor is connected to a red air tank. Two circular pressure gauges with white faces and black markings are mounted on the system. A red air hose is connected to a silver air gun. A coiled orange air hose is also visible. The background is a blurred industrial setting.

حلول العواء الممضفوط

هدود كومبروسورات



Air Compressor Head Pump



Features

- Aluminum parts for effective air cooling.
- Large oil pan for efficient lubrication of the interiors.
- HD plov is made of high hardness material and a heavy duty plant.
- The compression part is made of highly hard-wearing cast.
- Greater capabilities than compressors and air compressors).
- Safe for long-term use.
- Specially manufactured for heavy-duty applications.
- Instantaneous cooling at all stages of air compression in the throat with a two-stage press

المميزات

Technical details

المواصفات الفنية



Model	Liters/min	CFM	min-1	Cylinders	Stages	bar	psi	KW	HP	Code
● B2800B	255	9	1250	1	2	10	145	1.5	2	802314
	320	11.6	1570			10	145	2.2	3	
● B3800B	390	13.8	1100	1	2	10	145	2.2	3	802318
	480	16.9	1400			10	145	3	4	
● B4900B	514	18.1	1400	2	2	11	160	3	4	802312
● B5900B	653	23.3	1400	2	2	11	160	4	5.5	802315
● B6000B	827	29.2	1400	2	2	11	160	5.5	7.5	8023111
● B7000B	1210	42.7	1400	2	2	11	160	7.5	10	8023112
● K18/c	539	19	1400	1	2	11	160	4	3.5	802226
● K25	662	23.4	1280	2	2	11	160	4	5.5	802224
● K30	872	31	1150	2	2	11	160	5.5	7.5	802221
● K50	1240	43.8	1150	2	2	11	160	7.5	10	802222
● K60	1745	61.5	1190	2	4	11	160	11	15	802223
● K100	2148	75.68	1000	2	4	11	160	15	20	802225
● NB7	840	29.7	1250	2	2	11	160	5.5	7.5	802317
● NB10	1230	43.4	1250	2	2	11	160	7.5	10	802316



هدود كومبارسور Air Compressor Head Pump



Technical details

المواصفات الفنية

Model	Air Disp	RPM	Cylinders	Stages	bar	kW	HP	LxPxH cm	Kg	Code
● 2055Z	280	1100	10	2	8	1.5	2	28x21x22	11	802811
● 2065.Jumbo	330	1100	10	2	10	2.2	3	31x24x32	13	802812
● 2070.Jumbo	500	1100	10	2	10	3	4	31x24x32	15	802813
● 2080Z	600	1100	10	2	10	4	5.5	38x29x40	28	802815
● 2090Z	760	1000	10	2	10	5.5	7.5	38x29x40	30	802816

GEC
AIR COMPRESSOR

Direct Driven Series

كومبريسور هواء
Air Compressor



Tank Cap.
25/50/100 Liter

European Design 

UP TO 15 bar 

Copper Coils Inside 

Features

المميزات



- Direct driven air compressors operate more efficiently, consuming less energy and saving on operating costs due to the uninterrupted power transition from the motor to the pump

Technical details

المواصفات الفنية

Model	Liters	Liters/min	CFM	min-1	Cylinders Stages	bar	psi	KW	HP	Volt	Hz	LxPxH cm	Kg	Code
● YK24-2HP	25	200	8.5	2.850	1 1	8	116	1.5	2	220	50	59x25x61	21	80151
● YK2050-2HP	50	200	8.5	2.850	1 1	8	116	1.5	2	220	50	74x33x65	31	80152
● YK50-3HP	50	400	14	2.850	1 1	8	116	2.2	3	220	50	74x38x71.5	40	801514
● YK100-3HP	100	400	14	2.850	1 1	8	116	2.2	3	220	50	107x38x80	52	801515



Built In-Driven Series

كومبريسور هواء Air Compressor



European Design

UP TO 15 bar

Copper Coils Inside

Features

المميزات



- The belt driven air compressor is a good choice for different and heavy-duty applications as it is specially designed to give stable performance and long life. for the compressor

Technical details

المواصفات الفنية

Model	Liters	Liters/min	CFM	min-1	Cylinders Stages	bar	psi	kW	HP	Volt	Hz	L x P x H cm	Kg	Code
● 50LTR-2055Z	50	280	8.8	1,250	2 1	10	145	1.5	2	220	50	82x38x75	50	801516
● 50LTR-2065J	50	400	11.8	1,500	2 1	10	145	2.2	3	220	50	82x38x75	55	80156

GEC
AIR COMPRESSOR

Built In-Driven Series

كومبريسور هواء
Air Compressor



European Design 

UP TO 15 bar 

Copper Coils Inside 

Features

المميزات



- The belt driven air compressor is a good choice for different and heavy-duty applications as it is specially designed to give stable performance and long life. for the compressor

Technical details

المواصفات الفنية

Model	Liters	Liters/min	CFM	min-1	Cylinders Stages	bar	psi	kW	HP	Volt	Hz	LxPxH cm	Kg	Code
● 100LTR-2055Z	100	280	8.8	1,250	2 1	10	145	1.5	2	220	50	108x38x80	69	801517
● 100LTR-2065J	100	400	11.8	1,500	2 1	10	145	2.2	3	220	50	108x38x80	72	80157

GEC
AIR COMPRESSOR

Built In-Driven Series

كومبريسور هواء Air Compressor



European Design

UP TO 15 bar

Copper Coils Inside

Features

المميزات



- The belt driven air compressor is a good choice for different and heavy-duty applications as it is specially designed to give stable performance and long life. for the compressor

Technical details

المواصفات الفنية

Model	Liters	Liters/min	CFM	min-1	Cylinders	Stages	bar	psi	KW	HP	Volt	Hz	LxPxH cm	Kg	Code
● 200LTR-2055Z	200	300	11.3	1,500	2	1	10	145	1.5	2	220	50	150x50x103	105	80153
● 200LTR-2065J	200	450	11.6	1,550	2	1	10	145	2.2	3	220	50	150x50x103	115	801511

GEC
AIR COMPRESSOR

Built In-Driven Series

كومبريسور هواء
Air Compressor



European Design 

UP TO 15 bar 

Copper Coils Inside 

Features

المميزات



- The belt driven air compressor is a good choice for different and heavy-duty applications as it is specially designed to give stable performance and long life. for the compressor

Technical details

المواصفات الفنية

Model	Liters	Liters/min	CFM	min-1	Cylinders Stages	bar	psi	kW	HP	Volt	Hz	LxPxH cm	Kg	Code
● 300LTR-2065J	300	420	11.6	1.550	2 1	10	145	2.2	3	220	50	155x50x103	130	80155
● 300LTR-20701J	200	460	11.6	1.550	2 1	10	145	2.2	3	220	50	155x50x103	130	80154

shamal
Built In-Driven Series

كومبريسور هواء
Air Compressor



European Design

UP TO 15 bar

Copper Coils Inside

Features

Made in Italy

المميزات



- The belt driven air compressor is a good choice for different and heavy-duty applications as it is specially designed to give stable performance and long life. for the compressor

Technical details

المواصفات الفنية

Model	Liters	Liters/min	CFM	min-1	Cylinders Stages	bar	psi	kW	HP	Volt	Hz	L x P x H cm	Kg	Code
● SB28-100CM2	100	255	9	1250	1 2	10	145	1.5	2	220	50	103x44x85	61	80122



Built In-Driven Series

كومبريسور هواء Air Compressor



European Design 

UP TO 15 bar 

Copper Coils Inside 

Features

Made in Italy 

المميزات



Heavy Duty service



High performances



Energy saving



Highest flow rates



Long life



Low vibrations

- The belt driven air compressor is a good choice for different and heavy-duty applications as it is specially designed to give stable performance and long life. for the compressor

Technical details

المواصفات الفنية

Model	Liters	Liters/min	CFM	min-1	Cylinders Stages	bar	psi	kW	HP	Volt	Hz	L x P x H cm	Kg	Code
● SB28-200CM3	200	330	11.6	1570	1 2	10	145	2.2	3	220	50	103x44x92	68	801221
● SB28-200FTV4	200	480	16.9	1400	1 2	10	145	3	4	380	50	76X60X198	143	80122

shamal
Built In-Driven Series

كومبريسور هواء
Air Compressor



European Design

UP TO 15 bar

Copper Coils Inside

Features

Made in Italy

المميزات



Heavy Duty service



High performances



Energy saving



Highest flow rates



Long life



Low vibrations

- The belt driven air compressor is a good choice for different and heavy-duty applications as it is specially designed to give stable performance and long life. for the compressor

Technical details

المواصفات الفنية

Model	Liters	Liters/min	CFM	min-1	Cylinders Stages	bar	psi	kW	HP	Volt	Hz	L x P x H cm	Kg	Code
● SB28-270CM3	270	390	13.8	1100	1 2	10	145	2.2	3	220	50	164x56x119	142	80126
● SB28-270CT	270	390	13.8	1100	1 2	10	145	2.2	3	220	50	164x56x119	142	801216

shamal

Heavy Duty Series

كومبريسور هواء Air Compressor



European Design

UP TO 15 bar

Copper Coils Inside

Features

Made in Italy

المميزات



Heavy Duty service



High performances



Energy saving



Highest flow rates



Long life



Low vibrations

- The belt driven air compressor is a good choice for different and heavy-duty applications as it is specially designed to give stable performance and long life. for the compressor

Technical details

المواصفات الفنية

Model	Liters	Liters/min	CFM	min-1	Cylinders Stages	bar	psi	kW	HP	Volt	Hz	L x P x H cm	Kg	Code
● K30-500	500	582	20.6	800	2 2	10	145	5.5	7.5	380	50	201x65x119	142	8012212
● K50-500	500	390	30.3	800	2 2	10	145	7.5	10	380	50	227x56x166	333	8012213

shamal
Heavy Duty
Series

كومبريسور هواء
Air Compressor



European Design

UP TO 15 bar

Copper Coils Inside

Features

Made in Italy

المميزات



Heavy Duty service



High performances



Energy saving



Highest flow rates



Long life



Low vibrations

- The belt driven air compressor is a good choice for different and heavy-duty applications as it is specially designed to give stable performance and long life. for the compressor

Technical details

المواصفات الفنية

Model	Liters	Liters/min	CFM	min-1	Cylinders	Stages	bar	psi	KW	HP	Volt	Hz	L x P x H cm	Kg	Code
● B6000	500	1654	57.9	1400	2 ^o	2 ^o	11	160	5.5 ^o	7.5 ^o	380	50	201x65x119	142	801225
● K30-500	500	1744	60	1200	2 ^o	2 ^o	11	160	5.5 ^o	7.5 ^o	380	50	227x56x166	333	801219

shamal
Heavy Duty
Series

مصفاة زيت للبيارة تناسب زيت المواتير و زيت التروس Pit Gravity Waste Oil Drainer



European Design

UP TO 15 bar

Copper Coils Inside

Features

Made in Italy

المميزات



Heavy Duty service



High performances



Energy saving



Highest flow rates



Long life



Low vibrations

- The belt driven air compressor is a good choice for different and heavy-duty applications as it is specially designed to give stable performance and long life. for the compressor

Technical details

المواصفات الفنية

Model	Liters	Liters/min	CFM	min-1	Cylinders Stages	bar	psi	kW	HP	Volt	Hz	LxPxH cm	Kg	Code
● B6000	900	1654	57.9	1400	2 nd 2 nd	11	160	5.5 ^{kw}	7.5 ^{hp}	380	50	59x25x61	21	801230
● K30	900	1744	62	1200	2 nd 2 nd	11	160	5.5 ^{kw}	7.5 ^{hp}	380	50	74x33x65	31	801232
● B7000	900	2420	84.7	1400	2 nd 2 nd	11	160	7.5 ^{kw}	10 ^{hp}	380	50	74x38x71.5	40	801227
●	900	2148	76	1000	2 nd 2 nd	11	160	7.5 ^{kw}	10 ^{hp}	380	50	107x38x80	52	801228

GEC
Air Series

مواتير كهرباء
Electric Motors



Technical details

المواصفات الفنية

Model	Hp	⚡		Code
		Volt	Hz	
● GEC-M-2HP	2	220	50	802821
● GEC-M-3HP	3	220	50	802823
● GEC-M-5.5HP	5.5	380	50	802824
● GEC-M-7.5HP	7.5	380	50	802827
● GEC-M-10HP	10	380	50	802826



Pressure Switch Series



Electric Pressure Switch

مافتيح اوتوماتك

GEC-PS-380V

Technical details

● Min(Cut-in)	5 KFG/CM
● Max(Cut-off)	12 KFG/CM
● Differential	2-3 KFG/CM
● Factory Setting	F9-12 KFG/CM
● Electricity	20A/380V

المواصفات الفنية

● دقيقة (قطع)	5 كغ/سم
● ماكس (قطع)	12 كغ/سم
● تفاضل	2-3 كغ/سم
● إعداد المصنع	F9-12 كغ/سم
● كهرباء	20A/380V

40112



Technical details

● Min(Cut-in)	5 KFG/CM
● Max(Cut-off)	12 KFG/CM
● Differential	2-3 KFG/CM
● Factory Setting	F9-12 KFG/CM
● Electricity	20A/380V

المواصفات الفنية

● دقيقة (قطع)	5 كغ/سم
● ماكس (قطع)	12 كغ/سم
● تفاضل	2-3 كغ/سم
● إعداد المصنع	F9-12 كغ/سم
● كهرباء	20A/380V

40112

spare Parts قطع غيار

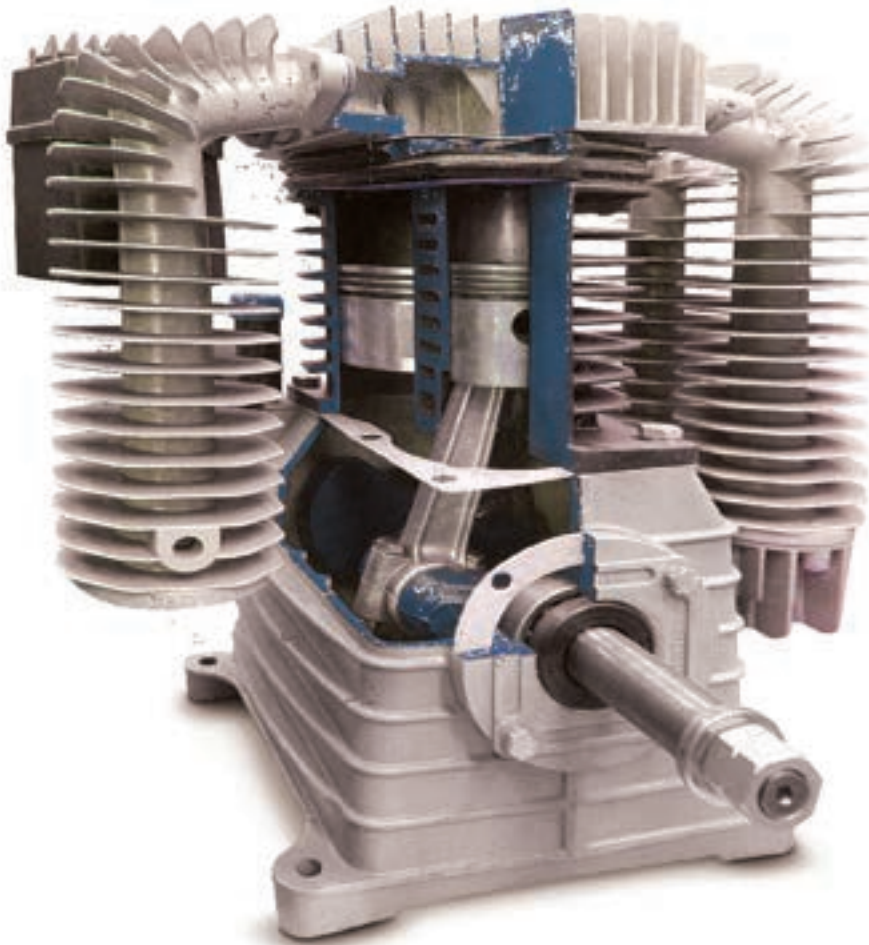

- Heavy Duty service
- Strong and Reliable
- High performances
- Long life
- Low vibrations
- Low speed
- From 2 to 20 HP
- Max 14 bar

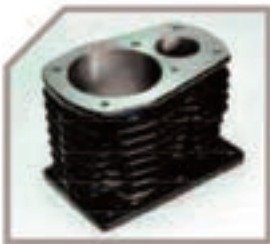

CYLINDERS

- In cast iron: strong, reliable, heavy duty
- Special machining to assure low oil consumption.



BEARINGS

- High quality ball bearings are the basis for ensuring a continuous service in all working conditions.



CRANKCASE

- High capacity of oil tank for longer autonomy
- Internal painting with resin against oil leaks
- No vibrations: big thickness of casting.



VALVES GASKET

- In stainless steel with cover of elastomers: assure perfect seal and long life in a very harsh conditions.



HEAD

- Alu die casting for a better dissipation of heat, with large fins for maximum cooling.



CRANKSHAFT AND CONNECTING ROD

- Crankshaft balanced with electronic equipment: no vibration
- Con-rod with low friction bushes to assure high efficiency and reduced wear.



AFTER COOLER

- Alu die casting for a better dissipation of heat
- Large fins for maximum cooling.



FILTER

- Labyrinth system to reduce noise
- Large Dust filter elements
- Long life.

FG GHOTTO

صامولة كمبروسور
Locking Nut1/4 Inch
803776/8 on zipper
80411

FG GHOTTO

بلبة صامولة كمبروسور
Confusion Nut Compressor6/8 on zipper
802510

FG GHOTTO

وصلة كاوتش صد رد
Wand Tyre Air Inflation Chuck150 mm
804327

FG GHOTTO

وصلة كاوتش صد رد
Wand Tyre Air Inflation Chuck30 mm
804323

FG GHOTTO

نبل بلاستيك / معدن ماجيك
Plastic Nipple Metal Magic8 mm x 1/4
80459

FG GHOTTO

عداد هواء
Air Meter4/1" rear inlet connection
Up to 12 bar Screen diameter 60 mm
804328

FG GHOTTO

عداد هواء
Air Meter4/1" rear inlet connection
Up to 12 bar Screen diameter 60 mm
8043211

FG GHOTTO

منظم هواء بالعداد
Regulator With Meter Air12 Bar 1/4 Inch
803112مسدس هواء
Air gun

8043105

خرطوم سوستة
Zipper hose8-6 mm x 15 M
80492مجفف هواء 1/2 بوصة 10 بار
Air Dryer 1/2 Inch 10 Bar

Features

المميزات

- The dryer removes moisture from the system thanks to the absorbing agent that's inside it, which is called silica gel.
- Silica gel has a uniform spherical size and is insoluble in water and organic solvents after moisture absorption from the air it does not expand and does not soften.

Technical details

المواصفات الفنية

- | | | |
|----------------------|------------|-----------------------|
| ● Output And Inlet | 1/2 Inch | ● الإخراج والمدخل |
| ● Inlet Air Pressure | 2 - 10 Bar | ● ضغط الهواء الداخل |
| ● Temperature Max | 50°C | ● درجة الحرارة القصوى |
| ● Weight | 9 Kg | ● ثقل |

803133



وصلات سريعة Quick Coupler



80443 Hose Tail 8mm



804411 Spring Hose 8mm



80442 1/4 Inch (Female)



80444 1/2 Inch (Male)

80445 1/4 Inch (Male)



لاكور وصلة سريعة Tail Connection Quick Coupler



80473 14mm *1/2 M Inch



804711 Spring Hose 8mm



80476 1/4 Inch



80472 8 mm



80474 1/4 Inch

80475 8mm*1/4 M Inch

80471 1/2 Inch



محبس بلية Ball Valve



بلف عدم رجوع هواء نحاس Brass No Return Valve

40431 1/4 Inch

804511 1/2 Inch

8041017 3/4 Inch



8041015

1 X 1

80410110

1 X 3/4

8041012

3/4 X 3/4

8041018

1/2 X 3/8

80453

Male x Male 1/2 X 1/2

8041019

Female x Female 1/2 X 1/2

8041011

3/8 X 3/8



نبيل قلاوظ Reducing Nipple

804524 2/1 X 4/1

804523 8/3 X 4/1



804522 2/1 X 8/3

804521 2/1 X 2/1



بلف امان Safety Valve

80410011 1/2 Inch

80410012 1/4 Inch



804124 1/2 Inch

804123 1/4 Inch



كوع ذكر وانثي Elbow Fitting



بلف عدم رجوع بلف امان No Return Valve Check Valve

404116 3/4 Inch

404124 1 Inch

404115 2 Inch



804510 3/8 Inch

404117 1/2 Inch

803114 1 Inch

803121 1/2 Inch

803115 1/4 Inch



منظم وفلتر هواء وزيت الكوباية بالجراب Air Filter & Regulator & Lubricator With Cover



Electric Motors

مواتير كهرباء Electric Motors



2-Poles 1.5kW 2HP



2-Poles 2.2kW 3HP



2-Poles 2.2kW 3HP



2-Poles 3kW 4HP



2-Poles 3kW 4HP



2-Poles 5.5kW 7.5HP



2-Poles 7.5kW 10HP



2-Poles 11kW 15HP



2-Poles 15kW 20HP

Technical details

المواصفات الفنية

Model	Hp	Volt	Hz	min-1	Code
● 2-Poles 1.5kW 2HP	2	220	50/60	2800	10521311
● 2-Poles 2.2kW 3HP	3	220	50/60	2800	105119
● 2-Poles 2.2kW 3HP	3	380	50/60	2800	803414
● 2-Poles 3kW 4HP	4	220	50/60	2800	10521319
● 2-Poles 3kW 4HP	4	380	50/60	2800	10521314
● 2-Poles 5.5kW 7.5HP	7.5	380	50/60	2800	10521312
● 2-Poles 7.5kW 10HP 10	10	380	50/60	2800	10521313
● 2-Poles 11kW 15HP	15	380	50/60	2800	10521315
● 2-Poles 15kW 20HP	20	380	50/60	2800	10521313



فرع الجمهورية

٥٥ شارع الجمهورية - وسط البلد - القاهرة

تليفون : ٢ / ٢٥٩٢٧٢٩٦

٢ / ٢٧٨٧٧١١٤

فاكس : ٢ / ٢٥٩١٢٧٠٣

فرع الهرم

٦٧ شارع الهرم - المريوطية - الجيزة

تليفون : ٢ / ٢٢٨٨٤٢٩٨

٢ / ٢٢٨٥٤٩١٢

فرع الدقهلية

٥٤ شارع عبدالسلام عارف - ميدان الساعة - الدقهلية

التواصل عن طريق الخط الساخن

01225 850 800   **HOTLINE**

 [youtube.com/gecegy](https://www.youtube.com/gecegy)

 [facebook.com\GECEGY.garageequipmentcenter](https://www.facebook.com/GECEGY.garageequipmentcenter)

sales@gecegy.com
customerservice@gecegy.com



www.gecegy.com

GEC